



# Installation Manual

## DuraVision® DX0211-IP

**IP Decoding Box**

**Software Version 5.3**

### **Important**

Please read this “Installation Manual”, “Instruction Manual”, and “Setup Manual” carefully to familiarize yourself with safe and effective usage.

- 
- For the latest product information including the “Installation Manual”, refer to our web site :

[www.eizoglobal.com](http://www.eizoglobal.com)

---

## Related Manuals

<b>Setup Manual</b>	Describes precautions and procedures for connecting network cameras and for displaying camera images on the monitor. (Installation and initialization guidance)
<b>Installation Manual (this manual)*1</b>	Describes network camera registration, function settings, and system settings. (Detail settings guidance)
<b>Instruction Manual*1</b>	Describes operation of live image screen menus. (Operation guidance)

\*1 The Instruction Manual and Installation Manual for the latest software version used can be obtained from our web site. Select "Manuals" from "Support", enter "DX0211-IP" in the "Enter model name" box, and click "Search".

[www.eizo.com](http://www.eizo.com)

Installation of Adobe® Acrobat® Reader® is required.

This product has been adjusted specifically for use in the region to which it was originally shipped. If operated outside this region, the product may not perform as stated in the specifications.

No part of this manual may be reproduced, stored in a retrieval system, or transmitted, in any form or by any means, electronic, mechanical, or otherwise, without the prior written permission of EIZO Corporation. EIZO Corporation is under no obligation to hold any submitted material or information confidential unless prior arrangements are made pursuant to EIZO Corporation's receipt of said information. Although every effort has been made to ensure that this manual provides up-to-date information, please note that EIZO product specifications are subject to change without notice.

# CONTENTS

<b>CONTENTS</b> .....	<b>3</b>	<b>Chapter 5 Live Image Screen Settings</b> .....	<b>54</b>
<b>Chapter 1 Product Overview</b> .....	<b>4</b>	5-1. Setting Display Positions of Camera Video Images.....	54
1-1. Features .....	4	5-2. Setting Display Methods of Camera Video Images.....	56
1-2. System Configuration .....	5	5-3. Setting Custom Screen Layouts .....	57
1-3. Supported Network Cameras .....	6	5-4. Changing the Displayed Layout Icon .....	58
<b>Chapter 2 Before Configuration</b> .....	<b>7</b>	5-5. Setting Layout Presets.....	59
2-1. Logging In to the System.....	7	5-6. Setting the Overlay .....	62
● Configuring from this product.....	7	5-7. Setting the Display Methods of Live Image Screens.....	64
● Configuring from a web browser .....	9	5-8. Setting Current Monitor Display Status...	65
2-2. Setting Screen.....	10	5-9. Checking Livestream View .....	66
● Basic Information .....	10	5-10. Refreshing the Livestream View .....	67
● System Settings .....	10	<b>Chapter 6 Management of the User Account</b> ...	<b>68</b>
● Live Image Screen Settings .....	10	6-1. Registering the User Account .....	68
<b>Chapter 3 System Settings</b> .....	<b>11</b>	6-2. Changing the User Account .....	70
3-1. Performing Network Settings.....	11	6-3. Deleting the User Account.....	71
3-2. Performing Communication Settings .....	13	6-4. Configuring Auto Login Settings.....	72
3-3. Setting the Current Date and Time .....	15	6-5. Performing LDAP Settings .....	73
3-4. Other System Settings .....	17	<b>Chapter 7 Troubleshooting</b> .....	<b>75</b>
3-5. Initializing the System.....	18	7-1. Imaging Problems.....	75
3-6. Restarting the System.....	19	7-2. Setting Problems .....	77
3-7. Updating Software .....	20	<b>List of Functions</b> .....	<b>78</b>
3-8. Saving Settings Data .....	22	<b>Appendix</b> .....	<b>80</b>
3-9. Loading System Settings Data.....	23	Trademark .....	80
3-10. Performing License Activation .....	25	License .....	80
3-11. Setting Event Rules .....	26		
3-12. Performing Certificate Settings .....	29		
3-13. Setting the Remote Control ID .....	31		
● Setting the product ID .....	31		
● Setting the remote control ID .....	32		
3-14. Configuring USB Device Hotkeys .....	33		
3-15. Checking Logs .....	35		
3-16. Saving Logs.....	36		
3-17. Performing Camera Connection Confirmation.....	37		
3-18. Confirming Network Connection Status...	38		
<b>Chapter 4 Management of Network Cameras</b> ...	<b>39</b>		
4-1. Registering a Network Camera Using Auto Discovery.....	39		
4-2. Registering a Network Camera Manually ...	41		
4-3. Changing Network Camera Information ...	44		
4-4. Deleting Network Cameras .....	46		
4-5. Exporting Network Camera Information...	47		
4-6. Importing Network Camera Information...	48		
4-7. Setting Network Camera Time .....	50		
4-8. Setting Quality of Transmission Video Images.....	51		

# Chapter 1 Product Overview

This product is a device that outputs video images from a maximum of 32 network cameras\*<sup>1</sup> to monitors connected using HDMI cable.

This manual describes network camera settings, system settings, and product specifications.

\*1 A type of camera which converts images into network signals and transmits the signals.

## 1-1. Features

### ● Communication with network cameras

- Possible to receive video images from a 4K camera (3840 × 2160 / 30 fps)
- Possible to display video signals from network cameras on a monitor
  - Supports H.264, H.265, and MJPEG compression formats.
  - A maximum of 48 network cameras can be registered.
  - Allows a free layout of video images (1 Screen, 3 Screens, 4 Screens, 9 Screens, 16 Screens, 32 Screens, 8 Screens, and Custom Screen) from multiple network cameras.
  - Supports Unicast and Multicast communication methods.
  - Possible to switch the display position of camera video images while displaying video images.

### ● Possible to output to a 4K monitor

- Supports 4K output (3840 × 2160 / 60 fps max.)

### ● Supports multiple types of network cameras

- Compatible with ONVIF Profile S
- Supports camera control using network camera manufacturer specific protocols  
(When connecting Panasonic or AXIS network cameras)

### ● System management

- Possible to register network cameras or set the live image screen using a Web browser
- Possible to save and load settings data  
Possible to save or load the setting data onto a computer.

### ● Security

- Alert display  
Possible to display an alert on the live image screen when communication with network cameras is lost.

### ● Supports secure communication

Utilizes SSL and TLS, which are secure protocols. Communication between network cameras and web pages is encrypted using SSL and HTTPS.

Purchase an Enterprise License to use LDAP authentication.

For details, contact your dealer or local EIZO representative.

- **Support**

- A 2-year long-term warranty for 24-hour continuous use

- **Operation**

- It is possible to operate using a keyboard, mouse, or joystick.

## 1-2. System Configuration

This system can communicate with network cameras, display video on the monitor that is connected to this product, and operate the network cameras.

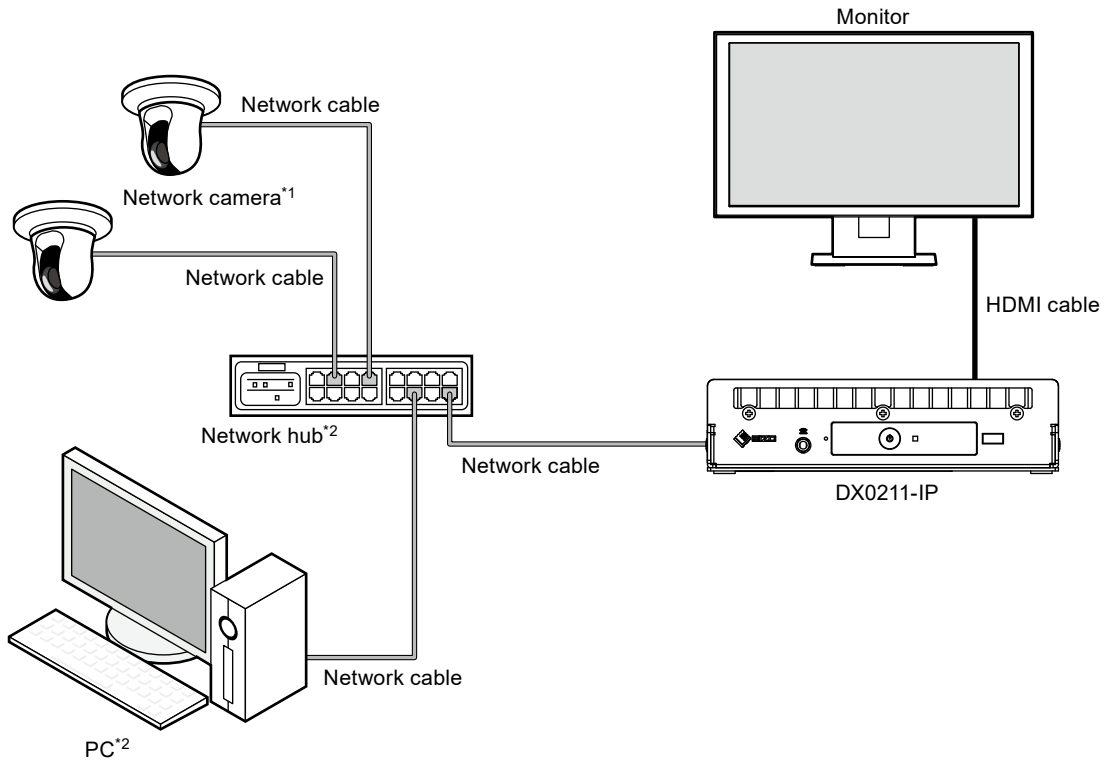

\*1 Up to 48 network cameras can be registered.

\*2 Use a network hub that supports PoE+. If the hub does not support the PoE+ standard, network cameras and DX0211-IP must be individually connected to the power supply.

\*3 When setting the network cameras using a Web browser, use a computer on the same network as the DX0211-IP.

## 1-3. Supported Network Cameras

---

This product supports the following network cameras:

- Panasonic i-pro series network cameras
- AXIS network camera
- ONVIF Profile S compatible network cameras

---

**Attention**

- Supported network cameras vary depending on the product's software version. Check the software version of the product you are using, then check our website ([www.eizoglobal.com](http://www.eizoglobal.com)) for details on supported network cameras. For information on how to check the software version, refer to "2-2. Setting Screen" (page 10).
- For installing and setting the network cameras, refer to the network camera User's Manual.

---

**Note**

- To verify the connection of a network camera, the image of the network camera can be accessed by specifying the URI. For details, refer to "4-2. Registering a Network Camera Manually" (page 41).
-

# Chapter 2 Before Configuration

System settings can be made from the screen (application screen) displayed on the monitor connected to the product or from the web browser of a computer connected to the same network.

## 2-1. Logging In to the System

To configure this product, you need to log in to the system.

Login is allowed only when the level of the user accessing the product is "ADMIN".

Log in to the system according to the following procedure.

### Note

- The following user information is set by default.
  - Username: "admin"
  - Password: "admin"
  - User Level: "ADMIN"
- For information on user settings, refer to "[Chapter 6 Management of the User Account](#)" (page 68).
- It is recommended that you log out after completing the setup, so as to prevent a third party from operating the network camera or altering the settings.
- When the Auto Login settings are configured, it is possible to log in to the system without the username and password.  
For details, refer to "[6-4. Configuring Auto Login Settings](#)" (page 72).

### ● Configuring from this product

A USB mouse is required when operating from the application screen.

Connect a USB mouse to the USB downstream port of this product.

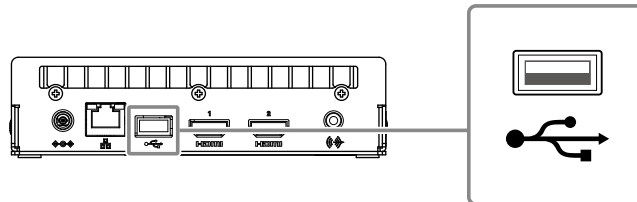

### Attention

- Adjust the monitor in advance so that the HDMI input can be displayed.

### Note

- Connecting to a device with USB hub function enables operation with multiple USB devices.
- For entering characters, refer to "[Entering characters](#)" (page 9).

### 1. Press on the front of this product.

The power indicator lights up blue and the live image screen is displayed on the monitor connected to this product.

(For information on the live image screen, refer to the "Instruction Manual".)

### Note

- The power supply is set to "On" by default.

## 2. Select (Login) under “System”.

The login screen is displayed.

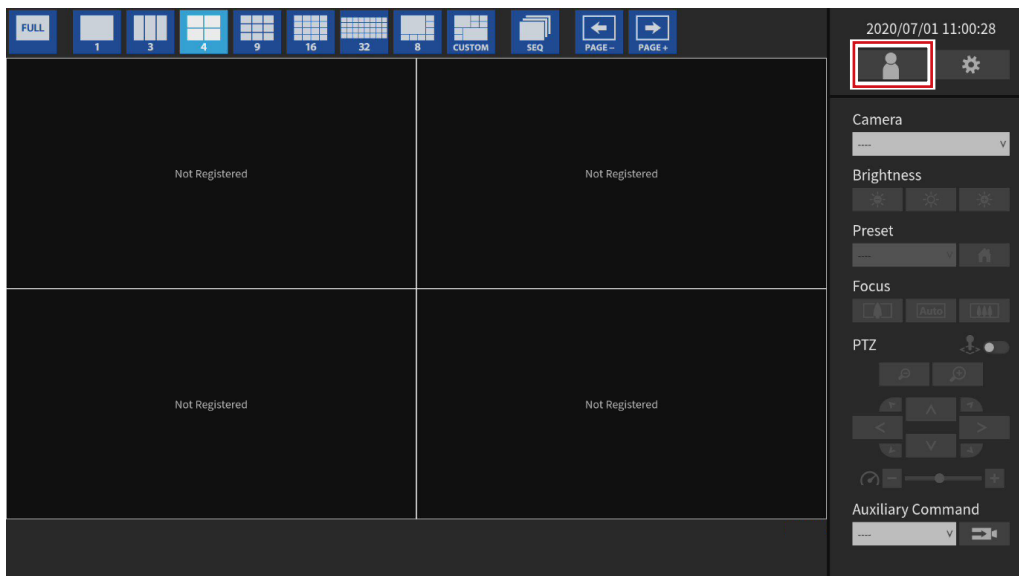

## 3. Enter “Username : ” and “Password : ”.

Login

Username :

Password :

Login Logout Cancel

---

### Note

- When the “Account Type” is set to “LDAP”, you can temporarily change the account type when logging in by checking “Allow choosing of account type on the login dialog.” under “LDAP” in advance.
- 

## 4. Select “Login”.

The display returns to the live image screen.

## 5. Select (Settings).

The setting screen is displayed.



## Entering characters

- When entering using a USB keyboard  
Typed characters are entered in the text box.
- When entering using a USB mouse  
Clicking an item that requires characters to be input, such as a text box, will display a software keyboard. When the focus is moved out of the software keyboard, the software keyboard is hidden.



## ● Configuring from a web browser

### Attention

- Web browser Microsoft Edge 79 or later is recommended.
- When configuring from the web browser, the power supply must be connected to this product.

### 1. Start the web browser of the PC to be used.

### 2. Enter the following address for access.

Address: [http://Address of this product\\*1](http://Address of this product*1)

\*1 The default address for access is <http://192.168.0.150>.

The login screen is displayed.

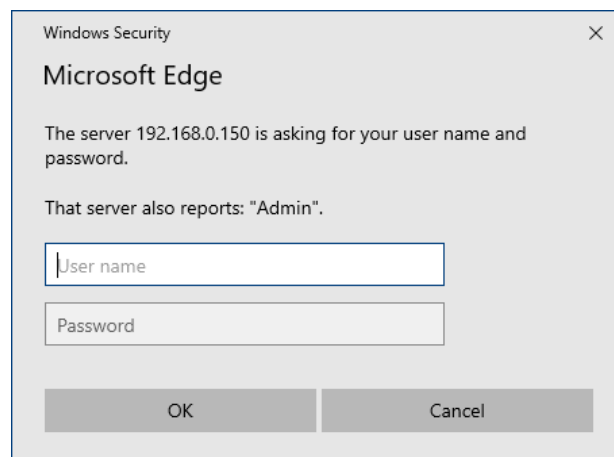

### 3. Enter a username and a password.

### 4. Select "OK".

The setting screen is displayed.

### Note

- If you are unable to login, try using the following address.  
<http://address of this product/index.html>

## 2-2. Setting Screen

The setting screen is comprised of “Basic Information”, “System Settings”, and “Live Image Screen Settings”.

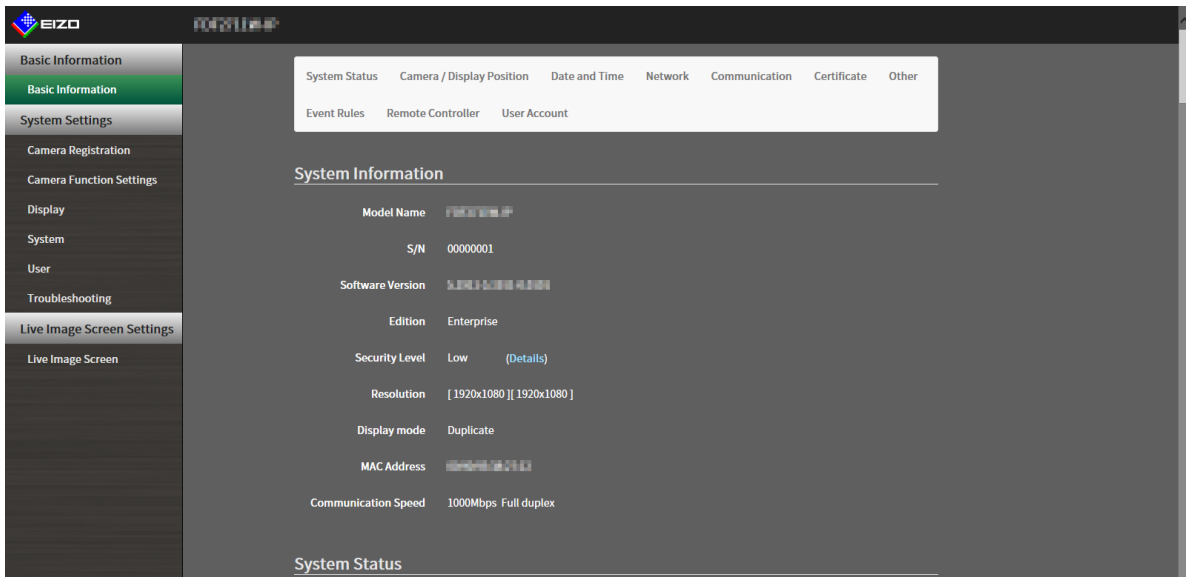

### ● Basic Information

Information on various settings of this product is displayed in a list. Clicking on an item tab at the top of the screen will display each setting item.

### System Information

Displays the current status.

- Model Name
- S/N
- Software Version
- Edition
- Resolution
- Display mode
- MAC Address
- Communication Speed
- Security Level (Enterprise Edition only)

### System Status / Camera / Display Position / Date and Time / Network / Communication / Certificate / Other / Event Rules / Remote Controller / User Account\*1

The current setting status is displayed.

\*1 Only available for use if the edition is Enterprise.

### ● System Settings

Various settings such as registration of network cameras and system settings are performed.

### ● Live Image Screen Settings

Display settings such as changing the live image screen layout are performed.

# Chapter 3 System Settings

Perform settings for the date and time of the system, network settings, and maintenance. These operations can be performed from the application screen or from the web browser. This chapter explains the procedure using the web browser. However, except for a few functions, the same functions can be used with either method.

## 3-1. Performing Network Settings

Perform network settings such as IP address, DNS, and NTP.

### Attention

- When any one of the IP address settings/IP address/subnet mask/gateway is changed and “Apply” is selected, the warning message “The network settings will be changed.” is displayed. Select “OK”.
- The same warning message is displayed when the IP address is changed from the web browser. Selecting “OK” will display a message requesting reaccess. Access again using the changed IP address.

### 1. Select “Network” of “System”.

The “Network” screen is displayed.

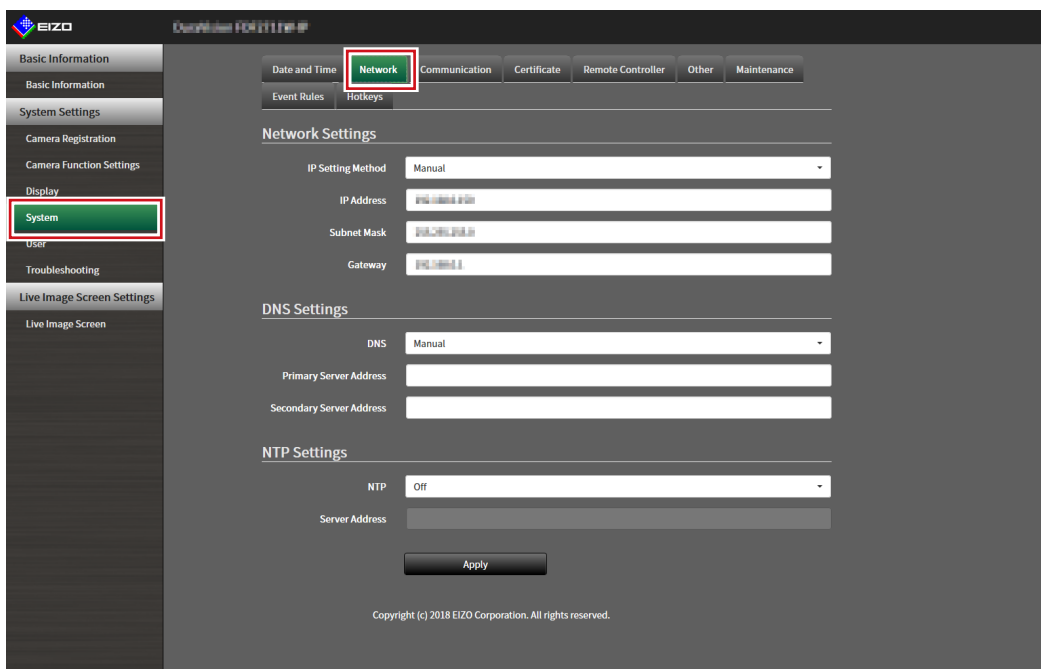

## 2. Set the following items.

### Network Settings

Item	Detail	Setting range
IP Setting Method	Select "IP Setting Method".	DHCP / Manual
IP Address <sup>*1</sup>	When "Manual" is selected under "IP Setting Method", "IP Address", "Subnet Mask", and "Gateway" can be set.	0.0.0.1 to 255.255.255.254
Subnet Mask		
Gateway <sup>*2</sup>		
	<b>Attention</b> <ul style="list-style-type: none"><li>• Avoid duplicate IP addresses for devices on the same network.</li><li>• If multiple units of this product are connected on the same network, their IP addresses should be changed.</li></ul>	

\*1 The initial address is "192.168.0.150".

\*2 If the environment does not include a gateway, it is not necessary to set "Gateway". Leave either as default setting or blank.

### DNS Settings

Item	Detail	Setting range
DNS	(Only when "Manual" is selected under "IP Setting Method" of "Network Settings") Set "DNS".	Auto / Manual
Primary Server Address	When "Manual" is selected under "DNS", set "Primary Server Address" and "Secondary Server Address".	0.0.0.1 to 255.255.255.254
Secondary Server Address		

### NTP Settings

Item	Detail	Setting range
NTP	Set whether to use the NTP server or not.	On / Off
Server Address	When "On" is selected, set the NTP server address.	Alphanumerics and symbols

## 3. Select "Apply".

The setting complete screen is displayed.

## 4. Select "OK".

## 3-2. Performing Communication Settings

The communication settings are used to configure the web interface function and detection of communication errors.

### 1. Select “Communication” of “System”.

The “Communication” screen is displayed.

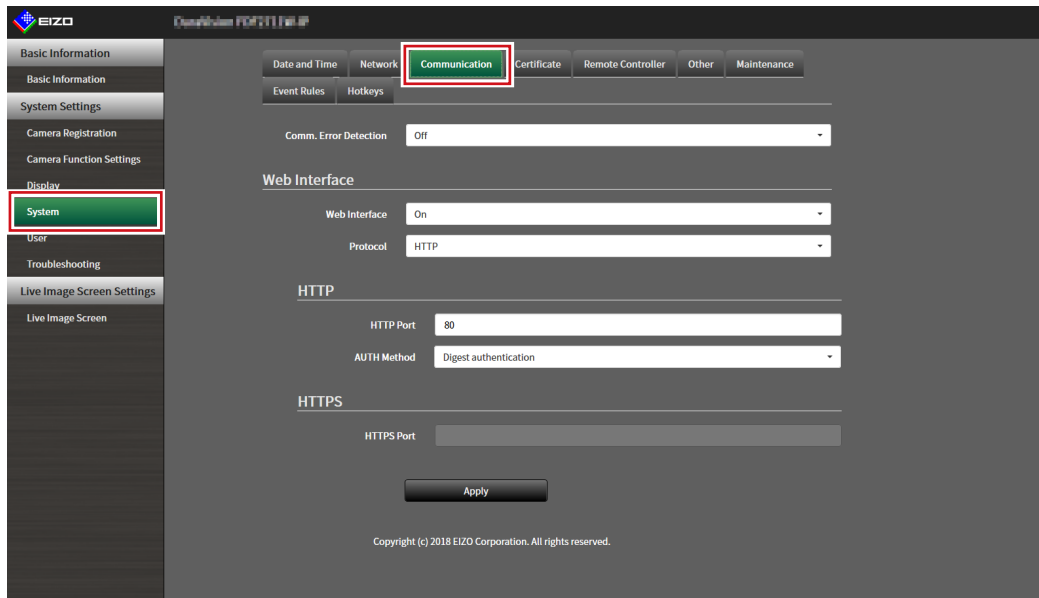

### 2. Set the following items.

Item	Detail	Setting range
Comm. Error Detection	Set the message display timing when the reception of video image data stops. On: Within several seconds after the reception of video image data stops, an alert message is displayed in a red box on the live image screen. When communication resumes, the alert is cleared and the video image is displayed again. Off: When approx. 30 seconds have elapsed after the reception of video image data stops, a communication error message is displayed.	On / Off
Web Interface	Enables operation and setting of the product over the network from a web browser.	On / Off <sup>*1</sup>
Protocol	Select protocol for communication with the web server. <sup>*2</sup>	HTTP / HTTPS <sup>*3</sup> / HTTP and HTTPS <sup>*3</sup>
HTTP Port	Set the HTTP port of the web interface.	80, 1024 to 65535
AUTH Method	Set the authentication method for the web interface. <sup>*4</sup>	Digest authentication / BASIC authentication
HTTPS Port	Set the HTTPS port of the web interface.	443, 1024 to 65535

\*1 If “USB Lock” is “On” and “Remote Controller Lock” is “On”, it cannot be set to “Off”.

\*2 Depending on the protocol selected, the address may be different when accessing this product from the web browser.

“HTTP”: http://address of this product

“HTTPS”: https://address of this product

“HTTP and HTTPS”: can be accessed from either of the above

\*3 Can be set when either “Self-Signed Certificate” or “CA-Signed Certificate” is selected in “Certificate”.

\*4 Cannot be set when “User Account” is “LDAP”.

### 3. Select “Apply”.

The setting complete screen is displayed.

### 4. Select “OK”.

---

**Attention**

- When “Web Interface” is set to “Off”, the settings cannot be configured from the web browser.
- When “Web Interface” is set to “Off” and “Apply” is selected, the following warning message is displayed.

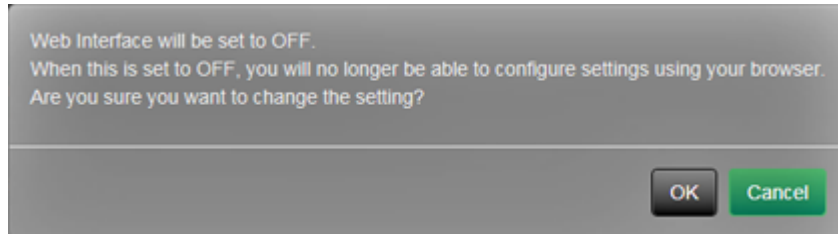

## 3-3. Setting the Current Date and Time

### Attention

- Set the correct dates. Incorrect dates may result in failure of secure communication during certificate validation. If you use SSL for communication with the camera or LDAP setting, avoid the state of power turned off for a long time of period or make sure correct time is set using NTP.
- If secure LDAP communication is not established, you can not login. Reset the account setting using the Reset button.

### 1. Select “Date and Time” of “System”.

The “Date and Time” screen is displayed.

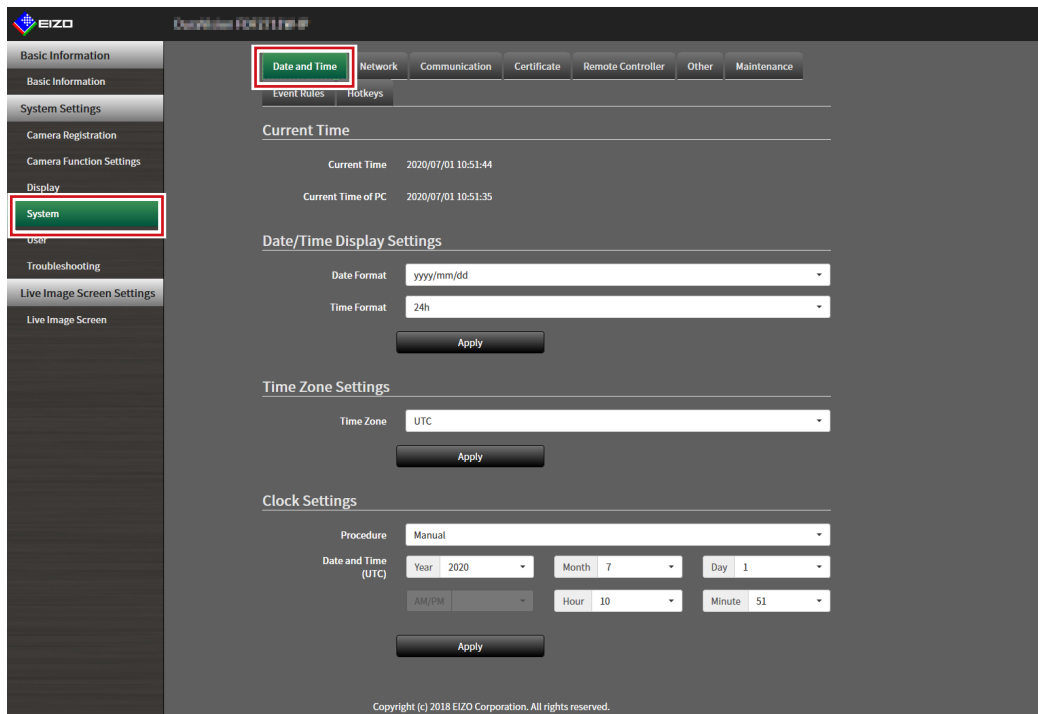

### 2. Set the current date and time.

#### Date/Time Display Settings

Item	Detail	Setting range
Date Format	Set the date format and time format.	yyyy/mm/dd, Mmm/dd/yyyy, dd/Mmm/yyyy, mm/dd/yyyy, dd/mm/yyyy
Time Format		

#### Time Zone Settings

Item	Detail	Setting range
Time Zone	Set the time zone.	Region / city

#### Clock Settings

Item	Detail	Setting range
Procedure <sup>*1</sup>	Select the time setting procedure.	Manual / Synchronize with PC
Date and Time	Set the current time.	2018/1/1 0:00 to 2035/12/31 23:59

\*1 This can be set only when displayed on the web browser.

### **3. Select “Apply”.**

The setting complete screen is displayed.

### **4. Select “OK”.**

---

**Note**

- When “Synchronize with PC” is selected for “Procedure”, the current date and time information of the computer is transmitted to this product.
  - If the system is not connected to the power supply for one week or longer, the date and time displayed on this product will become incorrect. If such a situation occurs, reset the date and time.
-



## 3-4. Other System Settings

Perform the following settings: “Language”, “Resolution”, “Multi-Monitor”, “Key Lock”, “USB Lock”, “Remote Controller Lock”, “Power Indicator”, and “Keyboard Layout”.

### 1. Select “Other” under “System”.

The “Other” screen is displayed.

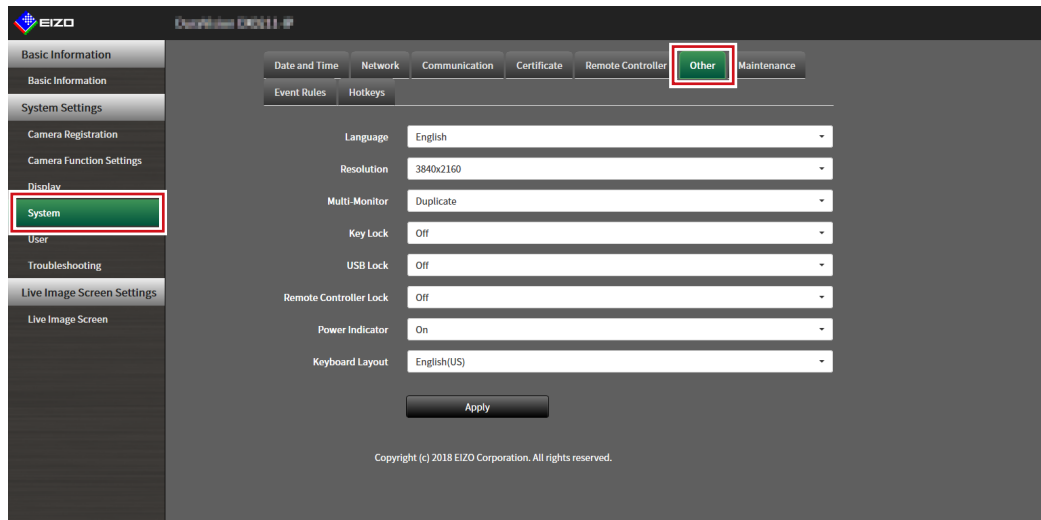

### 2. Set the following items.

Item	Detail	Setting range
Language	Set the display language of the menu and the setting screen.	日本語 / English / Deutsch
Resolution	Select an output resolution to the monitor.	1920x1080 / 2560x1440 / 3840x2160
Multi-Monitor	Select the method for outputting the signal from the HDMI connector 2.	Single / Extended / Duplicate
Key Lock	Locks operations by the buttons on the front of this product.	On / Off
USB Lock <sup>*1, 2</sup>	Locks operations of the USB device.	On / Off
Remote Controller Lock <sup>*1</sup>	Lock the operation of the remote control. (A function for use with models equipped with a remote control)	On / Off
Power Indicator	Sets whether to turn the power indicator (blue) on or off under normal operation.	On / Off
Keyboard Layout	Select the keyboard arrangement.	Japanese / English(US) / English(UK) / German

\*1 This can be set only when displayed on the web browser.

\*2 When the setting of “USB Lock” is changed, the product needs to be restarted.

### 3. Select “Apply”.

The setting complete screen is displayed.

### 4. Select “OK”.

## 3-5. Initializing the System

All settings are returned to default except for system logs, operation logs, the current time, time zone settings, license activation information, and the software version.

### 1. Select “Maintenance” of “System”.

The “Maintenance” screen is displayed.

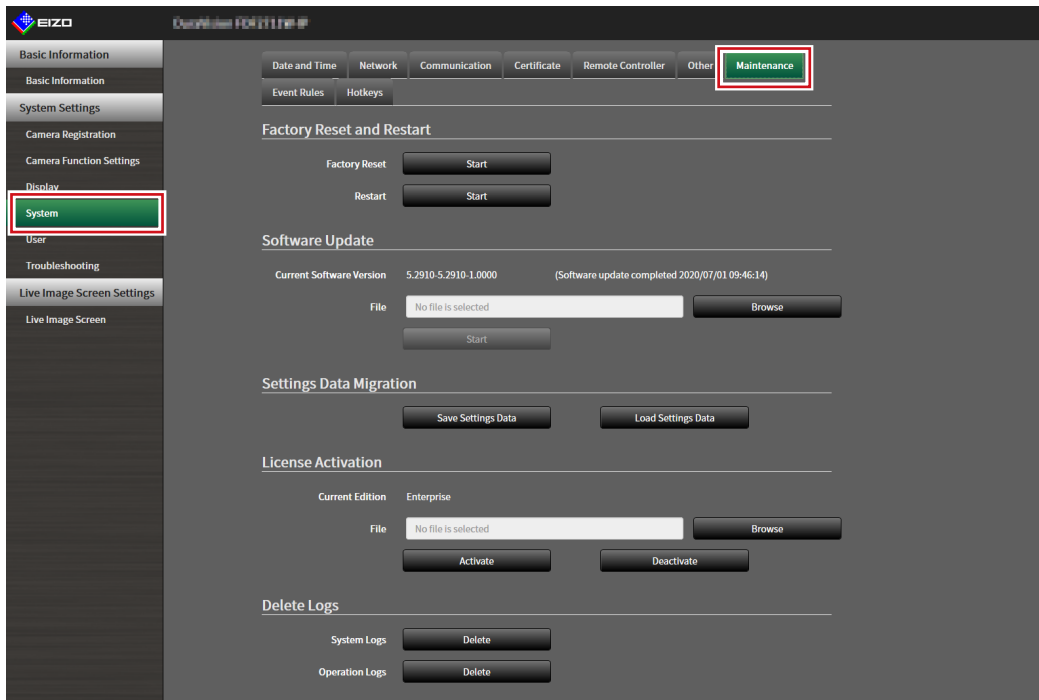

### 2. Select “Start” under “Factory Reset”.

A confirmation message is displayed.

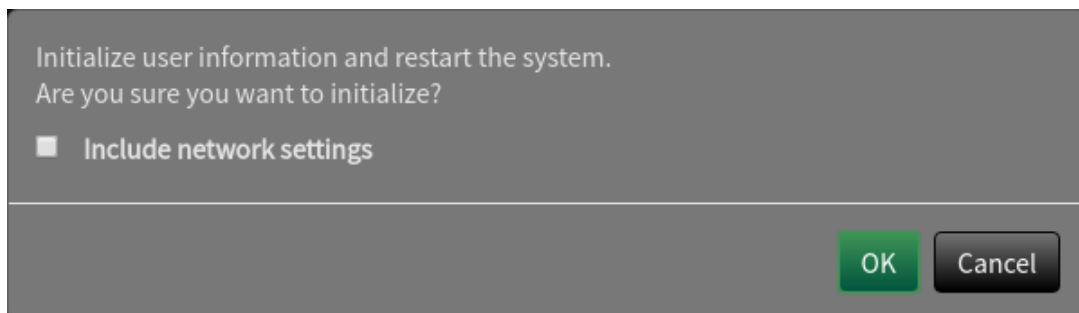

### 3. Check the box if you wish to include network settings in the factory reset.

### 4. Select “OK”.

## 3-6. Restarting the System

### 1. Select “Maintenance” of “System”.

The “Maintenance” screen is displayed.

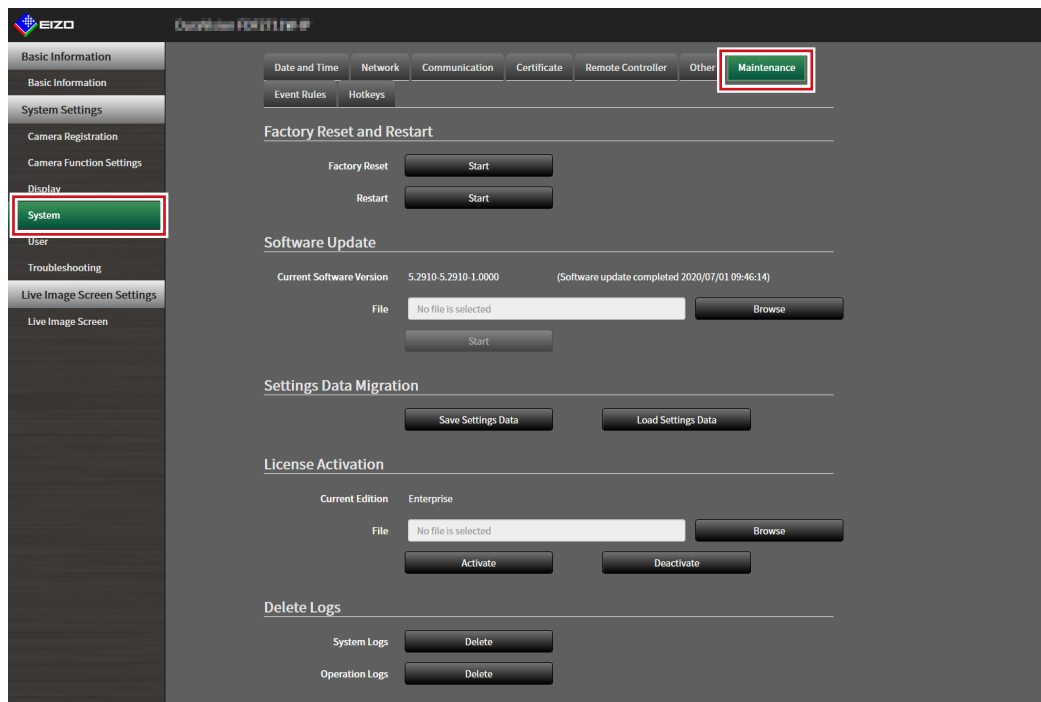

### 2. Select “Start” under “Restart”.

A confirmation message is displayed.

### 3. Select “OK”.

The system will restart.

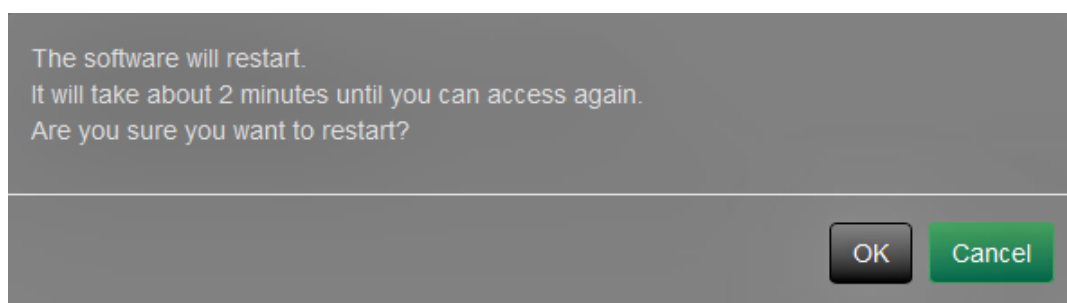

## 3-7. Updating Software

The software version can be upgraded. Download the upgrade file from the EIZO website ([www.eizoglobal.com](http://www.eizoglobal.com)) ahead of time.

### Attention

- This function can be used only when using the web browser.

### 1. Select “Maintenance” of “System”.

The “Maintenance” screen is displayed.

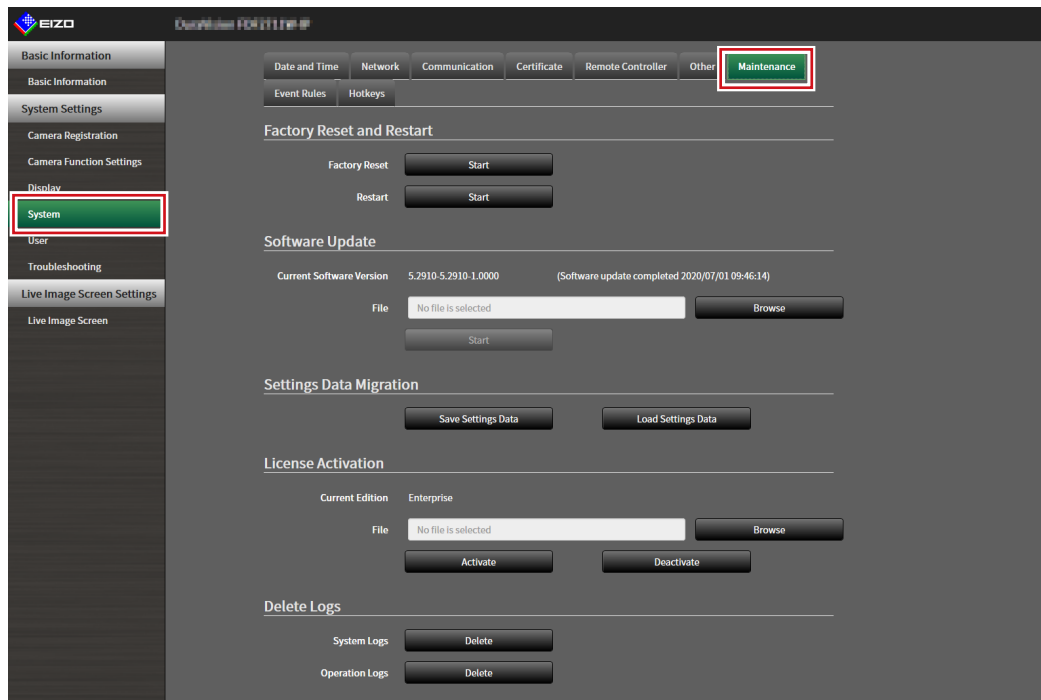

### 2. Select the upgrade file.

Select “Browse” under “Software Update” and set the file.

### Attention

- The software will not be updated if a file is not selected, or a file other than an update file has been selected.
- Update the software only when the power supply is connected to the product.

### 3. Select “Start”.

A confirmation message is displayed.

#### 4. Select “OK”.

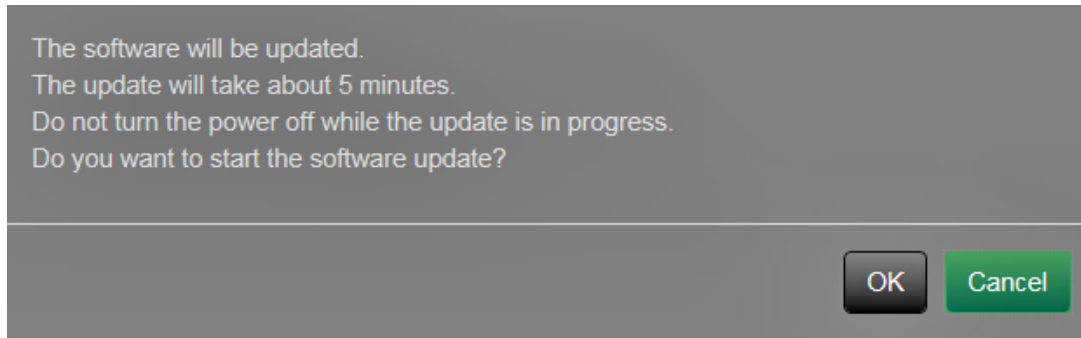

A “Software is being updated” message is displayed.

#### 5. Select “OK”.

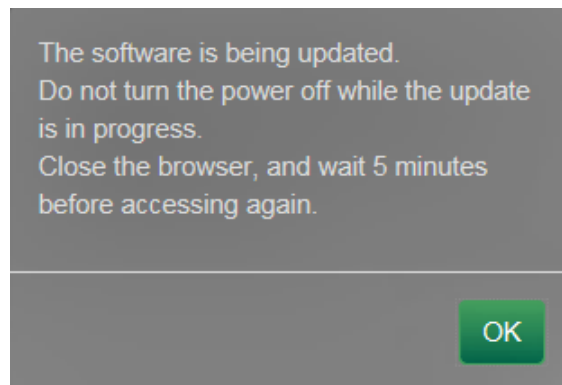

---

**Note**

- It takes approximately five minutes to update the software.
  - The red LED blinks while the software is updating.
-

## 3-8. Saving Settings Data

Settings data can be exported to a file. The exported file can be used to transfer settings data.

### Attention

- This function can be used only when using the web browser.

### 1. Select “Maintenance” of “System”.

The “Maintenance” screen is displayed.

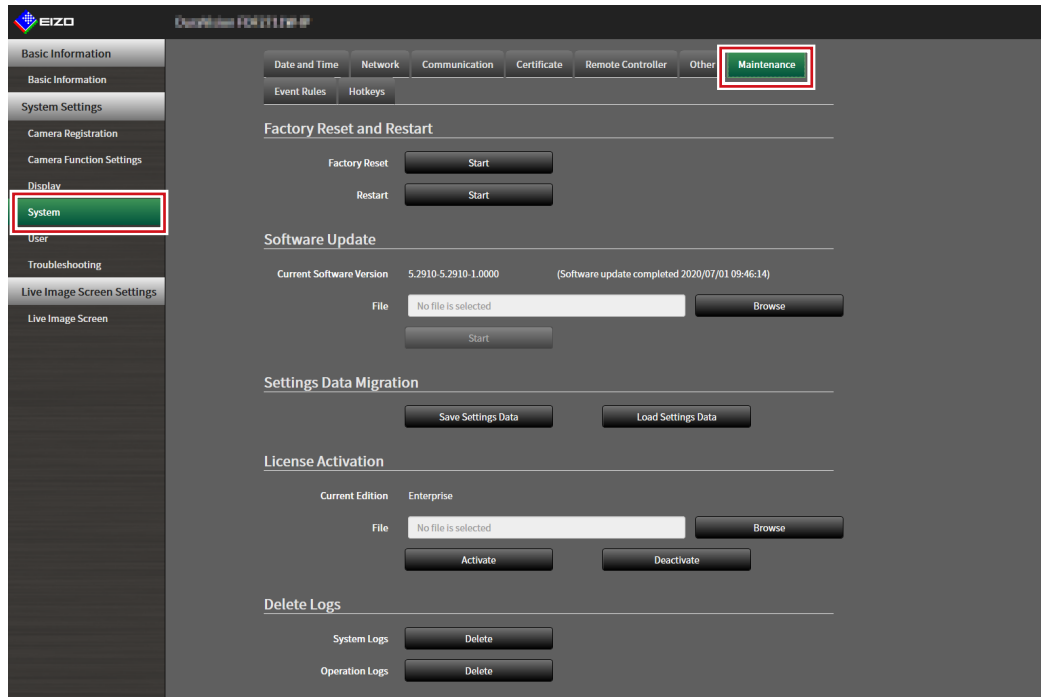

### 2. Select “Save Settings Data” under “Settings Data Migration”.

The “Save Settings Data” dialog box is displayed.

### 3. Specify the “Password”.

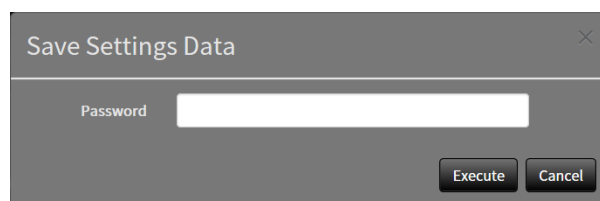

### 4. Select “Execute”.

### 5. Specify the saving destination.

The settings data is saved.

### Attention

- Some of the settings cannot be saved.
- If the password specified when saving the data is forgotten, it will no longer be possible to load the settings data.

### Note

- Saved file name: dx0211-ip\_Backupyyyyymmdd.duraconf2 (yyyyymmdd is the save date.)

## 3-9. Loading System Settings Data

Load settings data from a file.

### Attention

- This function can be used only when using the web browser.

### Note

- Regardless of the software version, it is possible to switch the LDAP settings.

### 1. Select “Maintenance” under “System”.

The “Maintenance” screen is displayed.

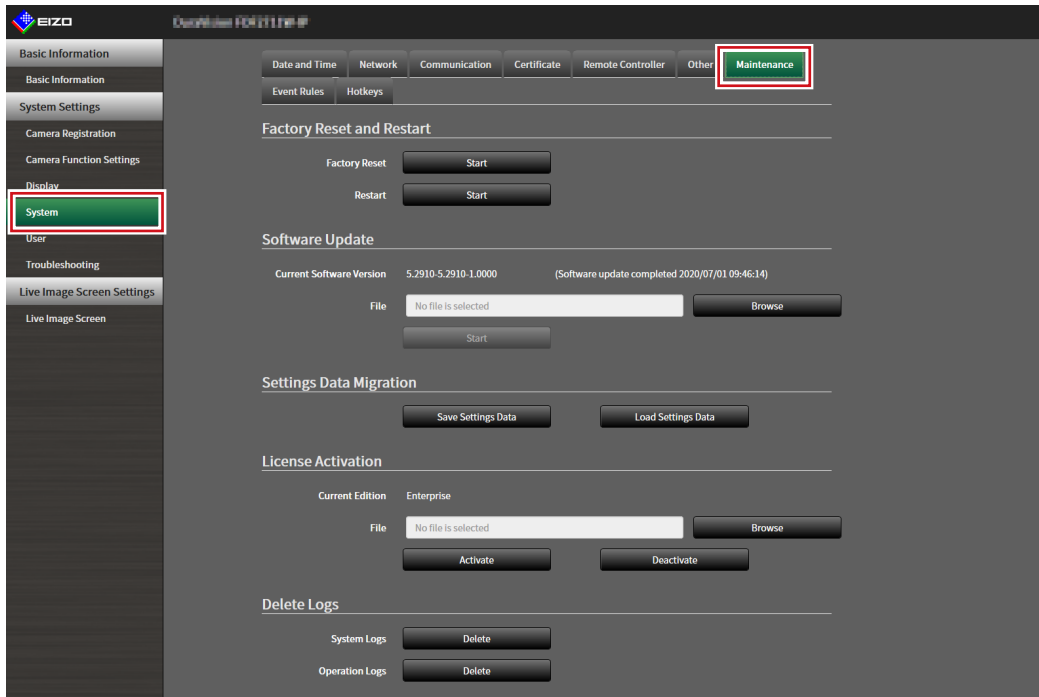

### 2. Select “Load Settings Data” under “Settings Data Migration”.

The “Load Settings Data” dialog box is displayed.

### 3. Select the settings data file.

Select “Browse” and set the file.

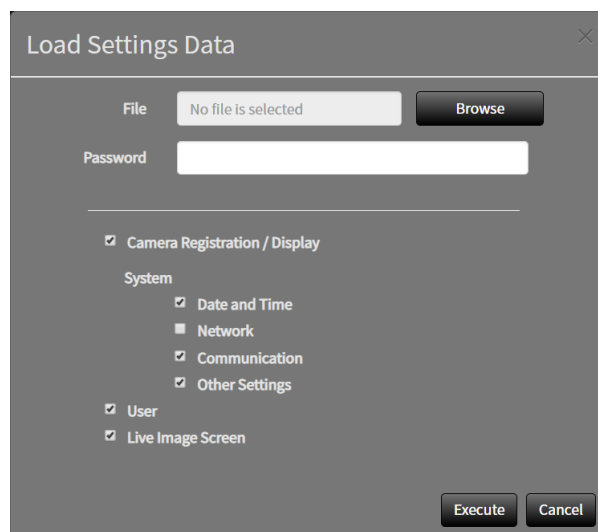

**4. Enter the password that was specified when saving the settings data in “Password”.**

**5. Select the data to be loaded.**

Place a check mark in the check box.

**6. Select “Execute”.**

When loading is completed, a message is displayed.

**7. Select “OK”.**

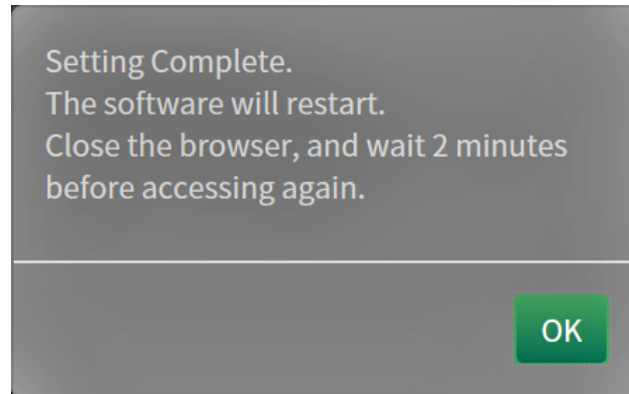

---

**Attention**

- If the environment where settings data was saved is different from the environment where settings data is loaded with respect to network settings or communication settings, you may not be able to display the settings screen from the web browser.
-



## 3-10. Performing License Activation

The software edition can be changed. Usable functions are added for Enterprise Edition. For details, contact your dealer or local EIZO representative.

### Attention

- This function can be used only when using the web browser.

### 1. Select “Maintenance” of “System”.

The “Maintenance” screen is displayed.

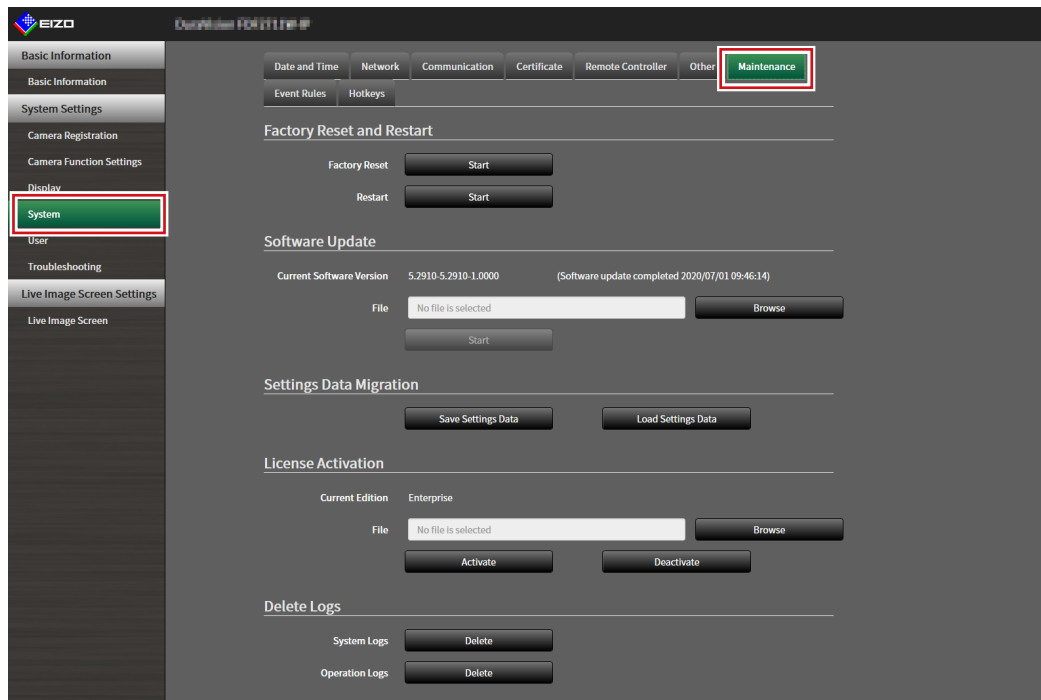

### 2. Select “Browse” for “License Activation”, and select the license file.

### 3. Select “Activate”.

A confirmation message is displayed.

### 4. Select “OK”.

“Current Edition” is updated to Enterprise.

Close the browser and wait 2 minutes before accessing again.

## 3-11. Setting Event Rules

Event rule is a function that executes specific actions when specific events are triggered. Actions to be executed when “Alert request received”, “Timer expired”, and “Video output status change” events occur can be set.

### Note

- A total of 16 individual Event Rules can be set.

### 1. Select “Event Rules” of “System”.

The “Event Rules” screen is displayed.

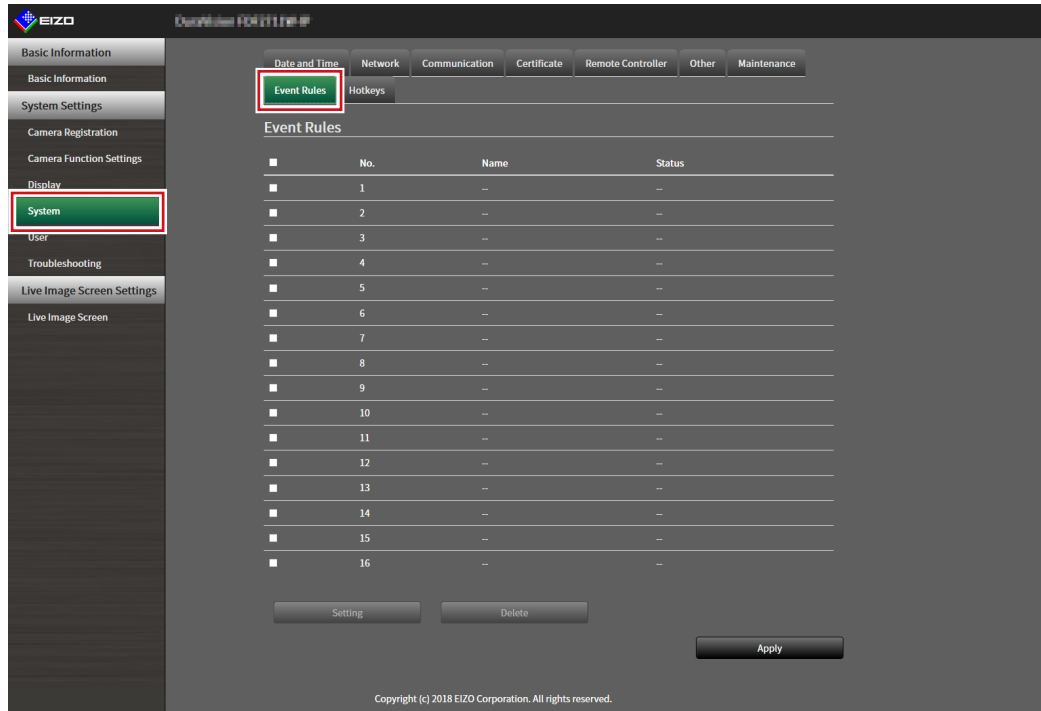

### 2. Select the number for registering the Event Rule.

Place a check mark in the check box of the number to be registered.

### 3. Select “Setting”.

The “Event Rules” screen is displayed.

## 4. Set Event Rules.

Item	Detail	Setting range
Name	Enter the name of the Event Rule.	Alphanumeric, kana <sup>*1</sup> , and kanji <sup>*1</sup> (Up to 24 characters)
Status	Select whether to enable or disable the Event Rule.	Active / Inactive
Event	Select an event to trigger an action. The items that can be set differ depending on the event. Refer to the tables below.	Alert request received / Timer expired / Auxiliary command <sup>*2</sup> / Video output status change
Action	Select the actions to be executed when an event occurs. The items that can be set differ depending on the action. Refer to the tables below.	Notification / Start a timer

\*1 This can be set only when displayed on the web browser.

\*2 Used when live image screen auxiliary command execution is set as a trigger. Camera auxiliary commands cannot be set as triggers.

### Selecting “Alert request received” as an “Event”

Item	Detail	Setting range
Camera No.	Select the camera to receive the alert.	Any, from 1 to 48
Trigger Type	Select the timing of the event to occur. Select “On” when setting display alert as a trigger, and “Off” when setting hide alert as a trigger.	Any / On / Off
ID <sup>*3</sup>	Select the ID.	Any, from 1 to 16

\*3 Can be set when the “Trigger Type” is “Any” or “On”.

### Selecting “Timer expired” as an “Event”

Item	Detail	Setting range
Timer No.	Select the number of the timer.	1 to 8

### Selecting “Notification” as an “Action”

Item	Detail	Setting range
Protocol	Select the communication protocol.	HTTP / HTTPS
URL	Enter the URL of the notification destination.	Alphanumerics and symbols (up to 32 characters)
Username	Enter the username for accessing the URL.	Alphanumerics and symbols (up to 32 characters)
Password	Enter the password for accessing the URL.	Alphanumerics and symbols (up to 32 characters)
Execute	Performs a confirmation test in order to access the specified URL.	

### Selecting “Start a timer” as an “Action”

Item	Detail	Setting range
Timer No.	Select the number of the timer.	1 to 8
Duration	Set “Minute” and “Second”.	“Minute”: 0 to 59, “Second”: 0 to 59

### 5. Select “OK”.

The settings are complete.

## 3-12. Performing Certificate Settings

### 1. Select “Certificate” of “System”.

The “Certificate” screen is displayed.

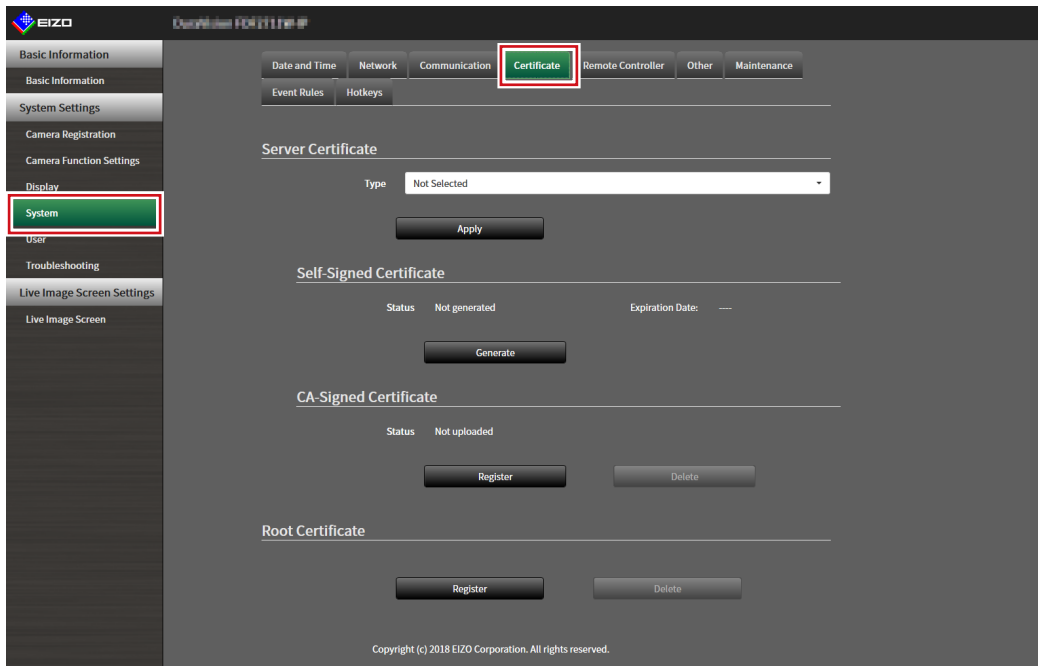

### 2. Perform certificate settings.

#### Server Certificate

The Server Certificate is used when accessing this product from the web browser via HTTPS.

#### Attention

- A Certificate Signing Request (CSR) cannot be created with this product.
- CA-Signed Certificate registration is only possible via web browser.

Select “Type”, and then select “Apply”.

#### • Self-Signed Certificate

Press the “Generate” button of the “Self-Signed Certificate” field to generate a certificate, and then select it.

#### • CA-Signed Certificate

Press the “Register” button of the “CA-Signed Certificate” field to register a certificate, and then select it.

Registration of information issued from the certifying body is required for registration.



## Root Certificate

The Root Certificate is used when performing an HTTPS connection with network cameras from this product, or when performing an LDAPS connection to the LDAP server.

---

**Attention**

- Root Certificate registration is only possible via web browser.
  - A Root Certificate is not pre-installed in this product.
- 

Select "Register", and then select "Root Certificate".



## 3-13. Setting the Remote Control ID

This function is for use with models equipped with a remote control.

When using multiple units of this product, the product operated by a remote control can be limited by specifying the ID shared by the product and remote control.

### Note

- When the remote control ID is “0” it will operate even if the product ID and remote control ID does not match.
- The factory value of the remote control is “0”.

## ● Setting the product ID

### 1. Select “Remote Controller” of “System”.

The “Remote Controller” screen is displayed.

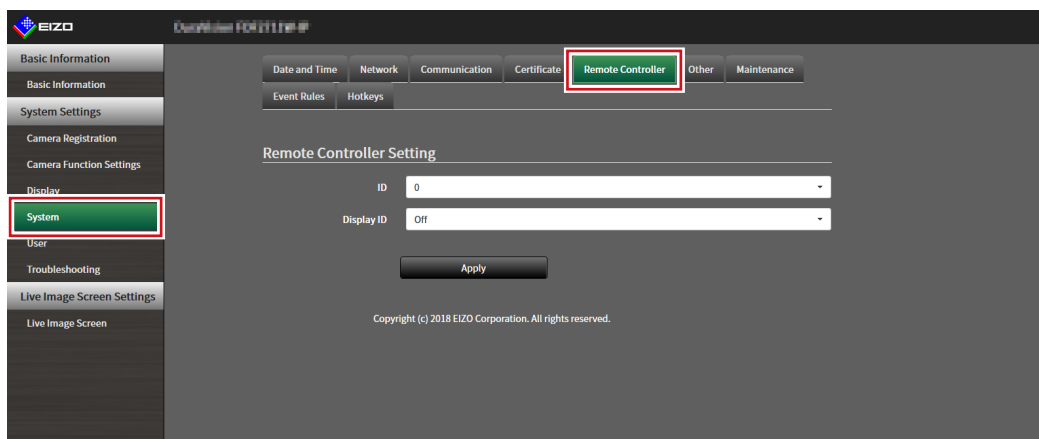

### 2. Set the following items.

Item	Detail	Setting range
ID	Select the number that will be the ID.	0 to 99
Display ID	When set to “On”, the ID is displayed in the upper right of the Live Image Screen when the ID button of the remote control is pushed.	On / Off

### 3. Select “Apply”.

The settings are complete.

## ● Setting the remote control ID

**1. Press and hold ID for more than 3 seconds.**

**2. With ID pressed, enter the ID (0 to 99) you want to set with the number buttons.**

---

**Note**

- If the ID you want to set is a single digit number, enter 0 before it.  
(Ex: To set “3”, enter “03”.)
- 

**3. Release ID.**

---

**Note**

- When confirming the ID of the remote control, set “Display ID ” to “On”, and press **ID**.  
The current ID is displayed in the upper right of the Live Image Screen.
-



## 3-14. Configuring USB Device Hotkeys

It is possible to operate the live image screen using the buttons on the USB device (excl. mouse, keyboard).

### Hinweis

- Supported USB devices are shown below.
  - AXIS T8311 (Joystick)

### 1. In „System“, select „Hotkeys“.

The „Hotkeys“ screen is displayed.

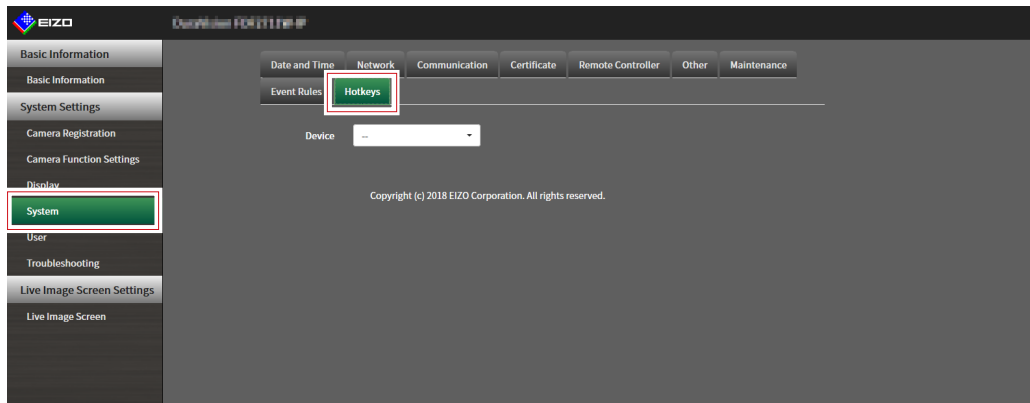

### 2. Select a USB device to be set from „Devices“.

A list of the selected USB device buttons is displayed.

### 3. Set the function of each button.

#### List of Functions

Element	Beschreibung
Vollbild	Displays/hides the live image screen menus.
1 Screen Layout	Changes the layout of the live image screen to 1 screen.
3 Screens Layout <sup>*1</sup>	Changes the layout of the live image screen to 3 screen.
4 Screens Layout <sup>*1</sup>	Changes the layout of the live image screen to 4 screen.
9 Screens Layout <sup>*1</sup>	Changes the layout of the live image screen to 9 screen.
16 Screens Layout <sup>*1</sup>	Changes the layout of the live image screen to 16 screen.
32 Screens Layout <sup>*1</sup>	Changes the layout of the live image screen to 32 screen.
8 Screens Layout <sup>*1</sup>	Changes the layout of the live image screen to 8 screen.
Custom Screen Layout <sup>*1</sup>	Changes the layout of the live image screen to Custom.
Sequence Mode	Turns the sequence display (mode that switches the pages to be displayed at regular intervals) of camera images on or off.
Page Up	Switches the camera images to be displayed on the live image screen to the next page.
Page Down	Switches the camera images to be displayed on the live image screen to the previous page.
Preset 1 <sup>*1</sup>	Changes the layout of the live image screen to preset 1.
Preset 2 <sup>*1</sup>	Changes the layout of the live image screen to preset 2.
Preset 3 <sup>*1</sup>	Changes the layout of the live image screen to preset 3.
Preset 4 <sup>*1</sup>	Changes the layout of the live image screen to preset 4.
Preset 5 <sup>*1</sup>	Changes the layout of the live image screen to preset 5.
Preset 6 <sup>*1</sup>	Changes the layout of the live image screen to preset 6.
Preset 7 <sup>*1</sup>	Changes the layout of the live image screen to preset 7.
Layout Change	Switches the layout of the live image screen each time the button is pressed.
JoyStick Mode <sup>*2</sup>	Switches Joystick Mode on or off.
Mouse Left <sup>*2</sup>	Mouse Left Click.

\*1 Can be set only when set to be displayed on the live image screen.

\*2 Is set as default on specific USB devices. Can be set only to buttons where it is the default setting.

#### AXIS T8311 Default Setting

Item	Description
J1	Full Screen
J2	Layout Change
J3	Page Up
J4	Page Down
L <sup>*3</sup>	Mouse Left
R <sup>*3</sup>	JoyStick Mode

\*3 Cannot be changed.

### 4. Select „Apply“.

## 3-15. Checking Logs

This system records operation logs and system logs. They can be used to check the current or past conditions of the system or to find out the cause when a problem occurs.

### 1. Select “Log Display” of “Troubleshooting”.

The “Log Display” screen is displayed.

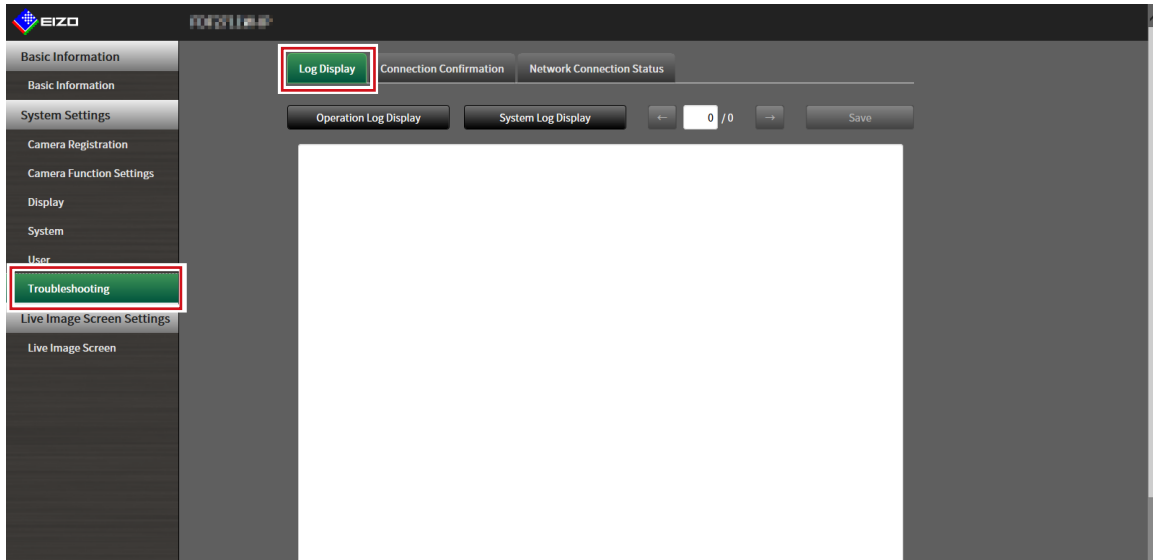

### 2. Select “Operation Log Display” or “System Log Display”.

The log is displayed in the lower area.

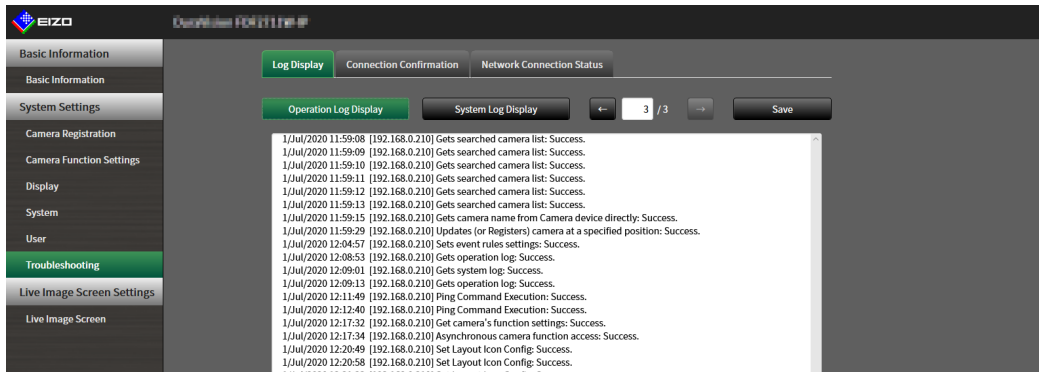

## 3-16. Saving Logs

Save operation logs and system logs.

Use these logs to check the current or past conditions of the system or to find out the cause when a problem occurs.

### Attention

- This function can be used only when using the web browser.

### 1. Select “Log Display” of “Troubleshooting”.

The “Log Display” screen is displayed.

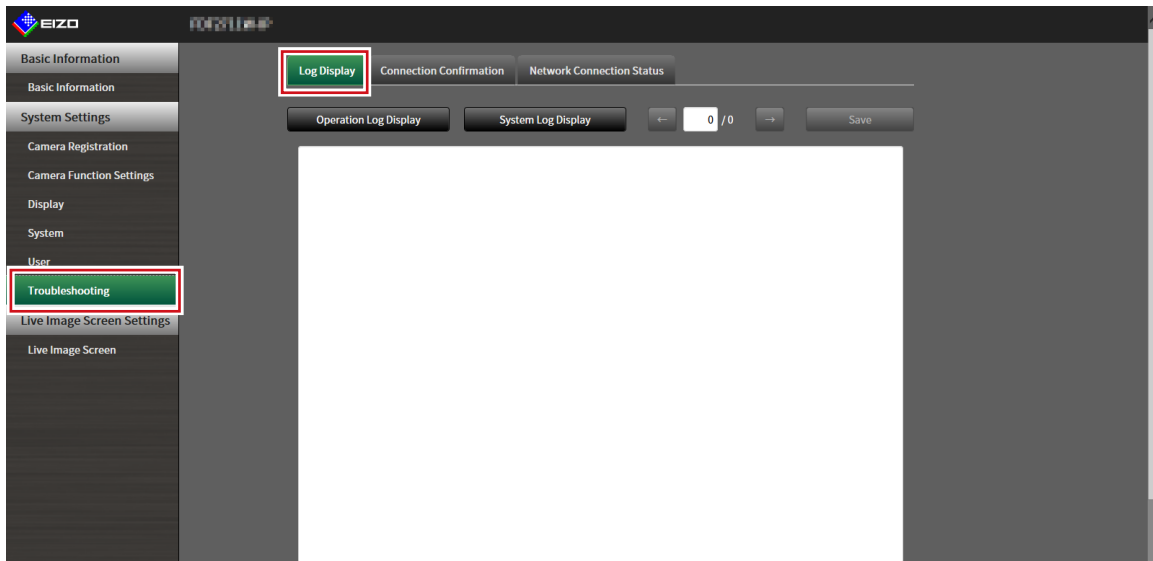

### 2. Select “Operation Log Display” or “System Log Display”.

The log is displayed in the lower area.

### 3. Select “Save”.

The saving destination dialog box is displayed.

### 4. Select a saving destination.

### 5. Select “Save”.

# 3-17. Performing Camera Connection Confirmation

The connection status of the network cameras can be confirmed.

**Attention**

- This function can be used only when using the web browser.

## 1. Select “Connection Confirmation” of “Troubleshooting”.

The “Connection Confirmation” screen is displayed.

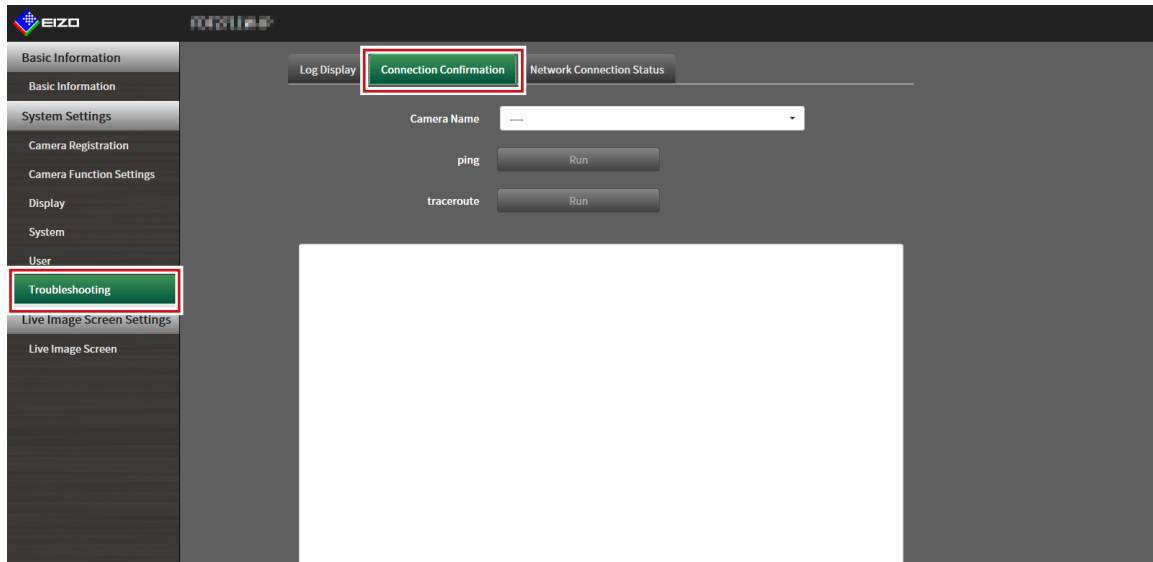

## 2. Select “Camera Name”.

## 3. Select “Run” for “ping” or “tracert”.

The connection status is displayed in the lower area.

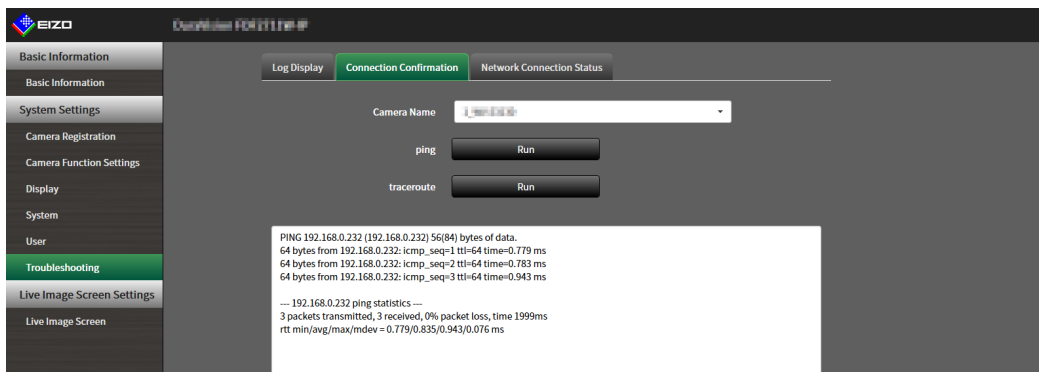

## 3-18. Confirming Network Connection Status

### 1. Select “Network Connection Status” of “Troubleshooting”.

The “Network Connection Status” screen is displayed.

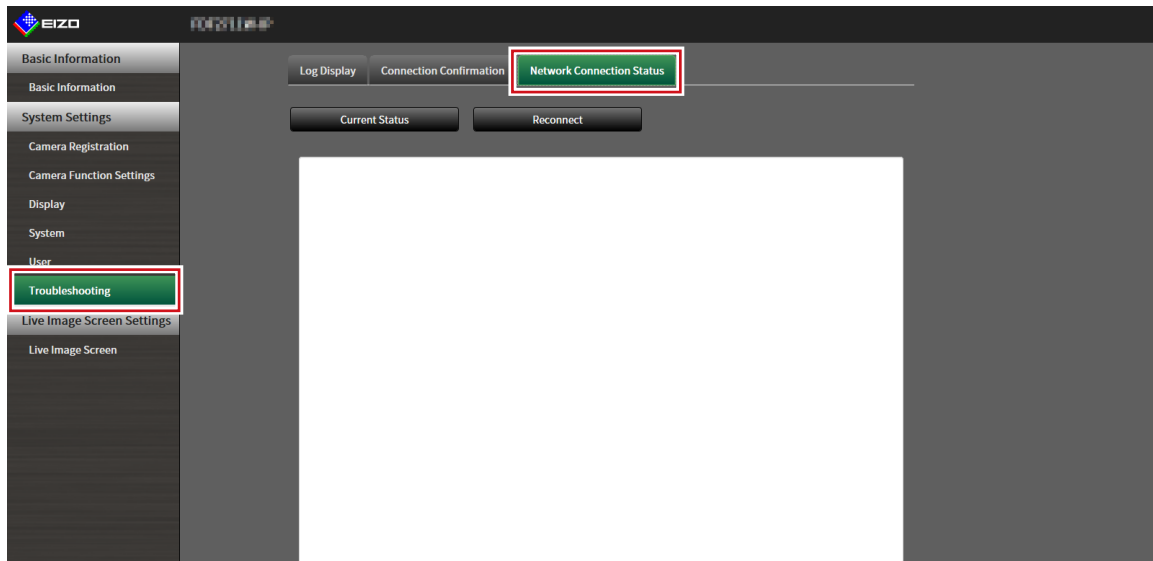

### 2. Select “Current Status”.

The connection status is displayed in the lower area.

---

**Note**

- Select “Reconnect” to reset the network status. The connection status is not displayed.
-

# Chapter 4 Management of Network Cameras

This section describes the procedure for network camera registration and function settings, and to reflect them on the system.

These operations can be performed from the application screen or from the web browser.

This chapter explains the procedure using the web browser. However, except for a few functions, the same functions can be used with either method.

## 4-1. Registering a Network Camera Using Auto Discovery

Network cameras installed on the same network as this product can be automatically detected and registered.

### 1. Select “Camera Registration”.

A screen is displayed to show a list of camera registration information.

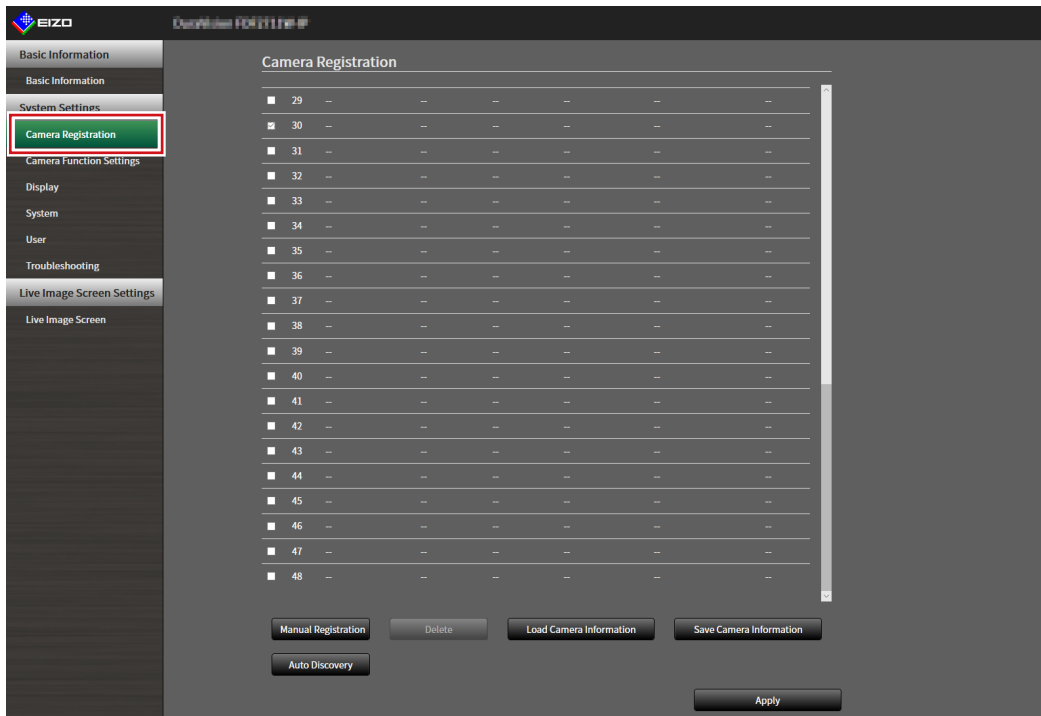

### 2. Select “Auto Discovery” in the lower part of the screen.

### 3. Select “Protocol”.

Select from “Panasonic”, “AXIS”, and “ONVIF”.

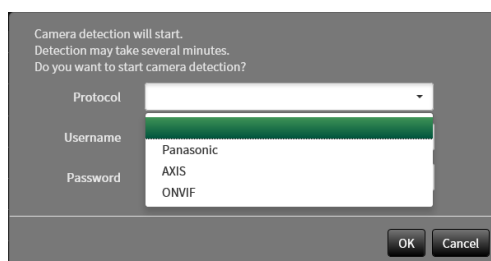

**4. Enter the network camera “Username” and “Password”, and select “OK”.**

Displays the detection results.

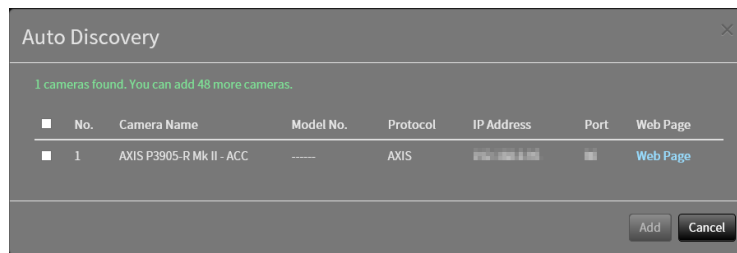

**5. Place a check in the camera to register, and select “Add”.**

The camera is registered.

**6. Select “Apply”.**



## 4-2. Registering a Network Camera Manually

### 1. Select “Camera Registration”.

A screen is displayed to show a list of camera registration information.

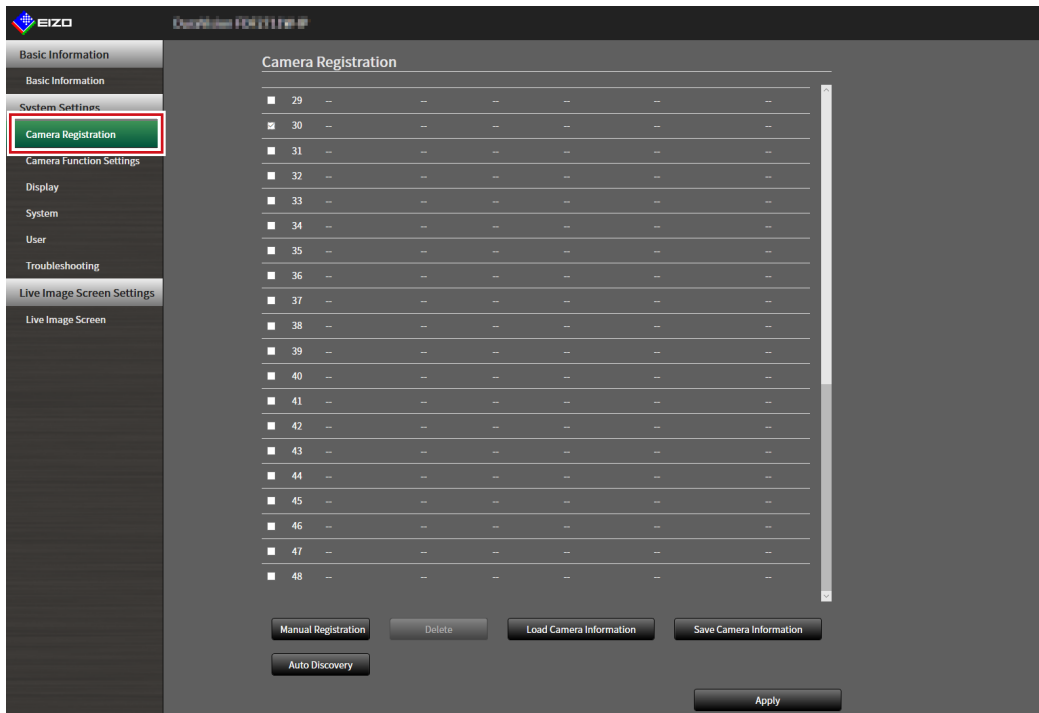

### 2. Select a position where the camera is to be registered.

Place a check mark on the check box of the position number where the camera is to be registered.

### 3. Select “Manual Registration” in the lower part of the screen.

The “Camera Information Settings” dialog box is displayed.

#### 4. Set each item and select “OK”.

Item	Detail	Setting range
Camera Name <sup>*1</sup>	Enter the camera name. If “Obtain Camera Name” is selected, the camera name is automatically obtained from the network camera. <sup>*2</sup> <ul style="list-style-type: none"> <li>If “Protocol” is “DirectUri”, “Obtain Camera Name” cannot be used.</li> </ul>	Alphanumeric, kana <sup>*3</sup> , and kanji <sup>*3</sup> (Up to 24 characters)
IP Address	Enter the IP address of the network camera.	0.0.0.1 to 255.255.255.254
“Ping” button	Executes a connection test with the camera (i.e. ping command).	-
Port	Enter the port number of the network camera.	1 to 65535 <sup>*4</sup>
SSL <sup>*5</sup>	Provides secure communication.	-
Certificate Validation	Select certificate validation during SSL communication. <b>Attention</b> <ul style="list-style-type: none"> <li>If “Certificate Validation” is “On,” the Root Certificate of the network camera must be registered in “Root Certificate” of “Certificate”.</li> </ul>	On / Off
Protocol	Select the protocol to control cameras.	Panasonic / AXIS / ONVIF / DirectUri
Username <sup>*6</sup>	Enter the user name to be used to access the network camera.	Alphanumerics and symbols (Up to 32 characters)
Password <sup>*6</sup>	Enter the password to be used to access the network camera.	Alphanumerics and symbols (Up to 32 characters)
Media Profile <sup>*7</sup>	Select the media profile of the network camera. Select “Obtain Profile” to obtain a list of profiles from the network camera.	EIZO_Profile / Profile of each camera
Transmission Mode <sup>*7</sup>	Select the mode for transmitting camera video images.	Unicast / Multicast
URI <sup>*8</sup>	Set the URI that starts with rtsp:// or rtp://.	Alphanumerics (Up to 1023 characters)
Comm. Method	Select the communication method for camera video images.	RTP over UDP <sup>*9</sup> / RTP over RTSP / SRTP over UDP <sup>*12</sup>
Stream <sup>*10</sup>	Select a stream format.	1 / 2 / 3 / 4
Channel <sup>*10</sup>	Select a stream channel.	1 / 2 / 3 / 4
RS485PTZ Control <sup>*10</sup>	Select whether or not PTZ operation is enabled for the camera that supports RS 485 communication.	On / Off
Video Stream <sup>*11</sup>	Select a video stream format.	Depends on the camera
Stream Profile <sup>*11</sup>	Select a stream profile.	Depends on the camera

- \*1 This can be obtained only when “IP Address”, “Port”, “Username”, and “Password” are input.
- \*2 If “Protocol” is “DirectUri,” the “Obtain Camera Name” button is not displayed.
- \*3 This can be input only when displayed on the web browser.
- \*4 When “Protocol” is set to “DirectUri” and “URI” starts with rtp://, the setting range will be 1024 to 65534.
- \*5 Can only be set if “Protocol” is “Panasonic”, “AXIS”, or “ONVIF”.
- \*6 Enter the username and password of the user who has the administrator’s rights. For details, refer to the network camera User’s Manual.
- \*7 This can be set only when “Protocol” is set to “ONVIF”.
- \*8 This can be set only when “Protocol” is set to “DirectUri”.
- \*9 In the following cases, it is only possible to set “RTP over UDP”.
  - In the case where “Protocol” is set to “ONVIF” and “Transmission Mode” is set to “Multicast”
  - When “Protocol” is set to “DirectUri” and “rtp://Multicast Address” is correctly entered into URI
- \*10 This can be set only when “Protocol” is set to “Panasonic”.
- \*11 This can be set only when “Protocol” is set to “AXIS”.
- \*12 Can be set upon fulfilling all of the following conditions.
  - Using Enterprise edition
  - “Protocol” is “AXIS”
  - “SSL” is checked
  - Camera SRTP setting is enabled

Returns to the screen that shows a list of camera registration information in the step 1 above.

## 5. Select “Apply”.

A confirmation message is displayed.

## 6. Select “OK”.

---

### Note

- If there is a failure in obtaining “Obtain Camera Name” or “Obtain Profile” information, the following message is displayed. Try obtaining the information again.

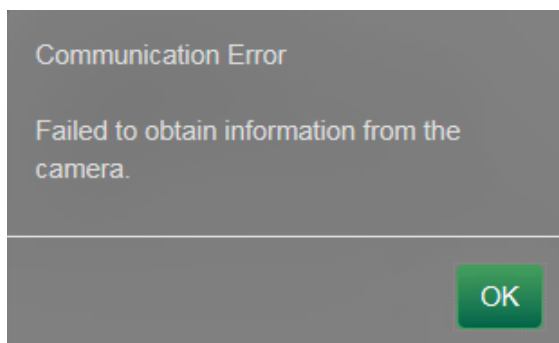

## 4-3. Changing Network Camera Information

### 1. Select “Camera Registration”.

A screen is displayed to show a list of camera registration information.

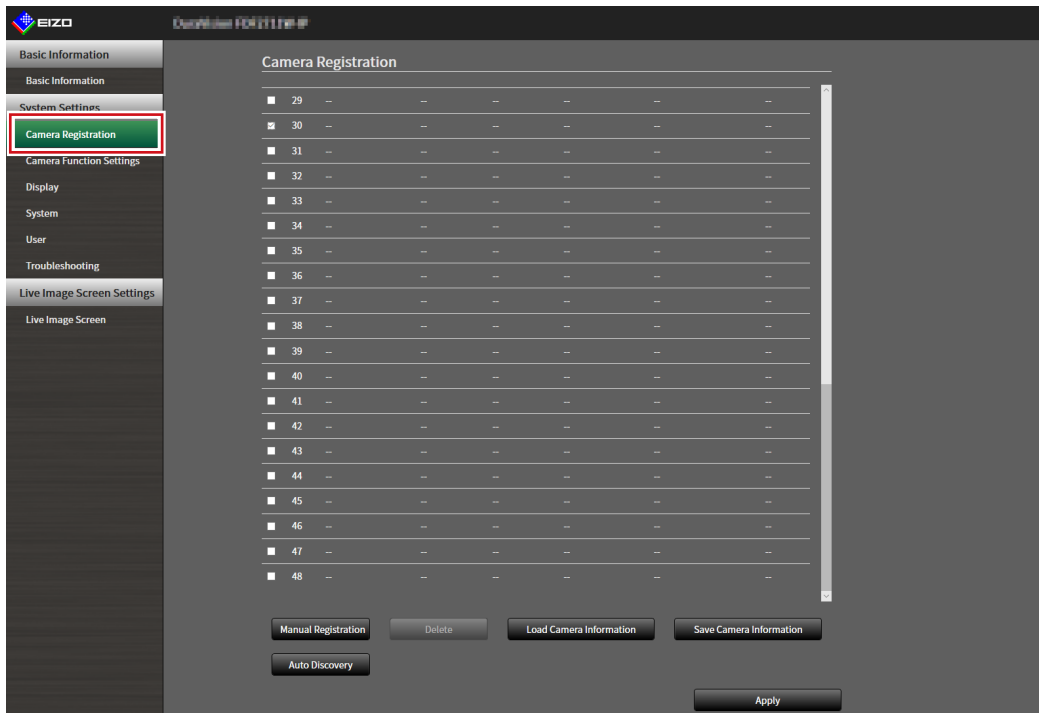

### 2. Select the position number of the camera to be changed.

Place a check mark on the check box of the position number of the camera to be changed.

### 3. Select “Manual Registration”.

The “Camera Information Settings” dialog box is displayed.

### 4. Set each item and select “OK”.

Returns to the camera registration information list screen in step 1.

Display Position 3

Camera Name  Obtain Camera Name

IP Address  Ping

Port

SSL

Certificate Validation Off

Protocol Panasonic

Username

Password

Stream 2

Channel 1

RS485PTZ Control Off

Comm. Method RTP over UDP

OK Cancel

#### Note

- For details, refer to step 3 under “4-2. Registering a Network Camera Manually” (page 41).

## 5. Select “Apply”.

A confirmation message is displayed.

## 6. Select “OK”.

---

### Note

- If there is a failure in obtaining “Obtain Camera Name” or “Obtain Profile” information, the following message is displayed. Try obtaining the information again.

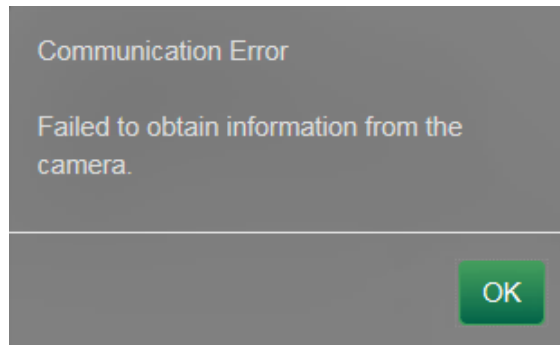

## 4-4. Deleting Network Cameras

### 1. Select “Camera Registration”.

A screen is displayed to show a list of camera registration information.

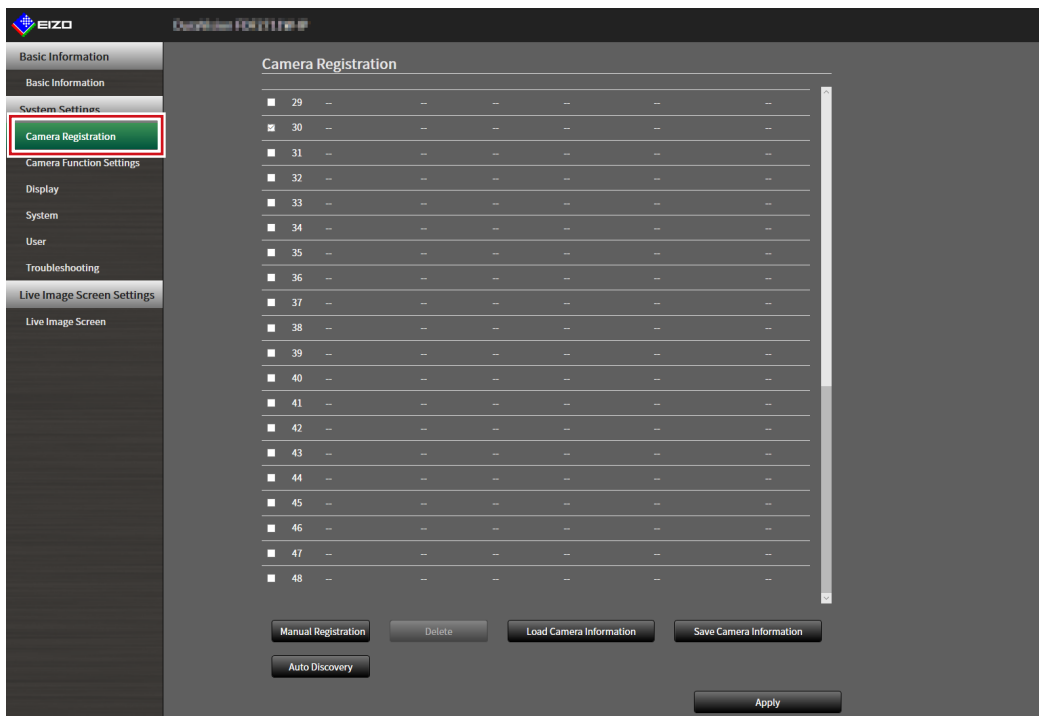

### 2. Select the camera to be deleted.

Place a check mark on the check box of the position number of the camera to be deleted.

### 3. Select “Delete” in the lower part of the screen.

A confirmation message is displayed.

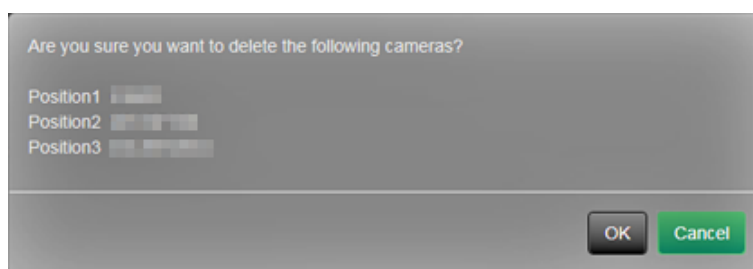

### 4. Select “OK”.

Returns to the screen that shows a list of camera registration information.

### 5. Select “Apply”.

A confirmation message is displayed.

### 6. Select “OK”.

## 4-5. Exporting Network Camera Information

The list of camera registration information can be saved in a CSV file.

The exported file can be used when transferring network camera information.

### Attention

- This function can be used only when using the web browser.

### 1. Select “Camera Registration”.

A screen is displayed to show a list of camera registration information.

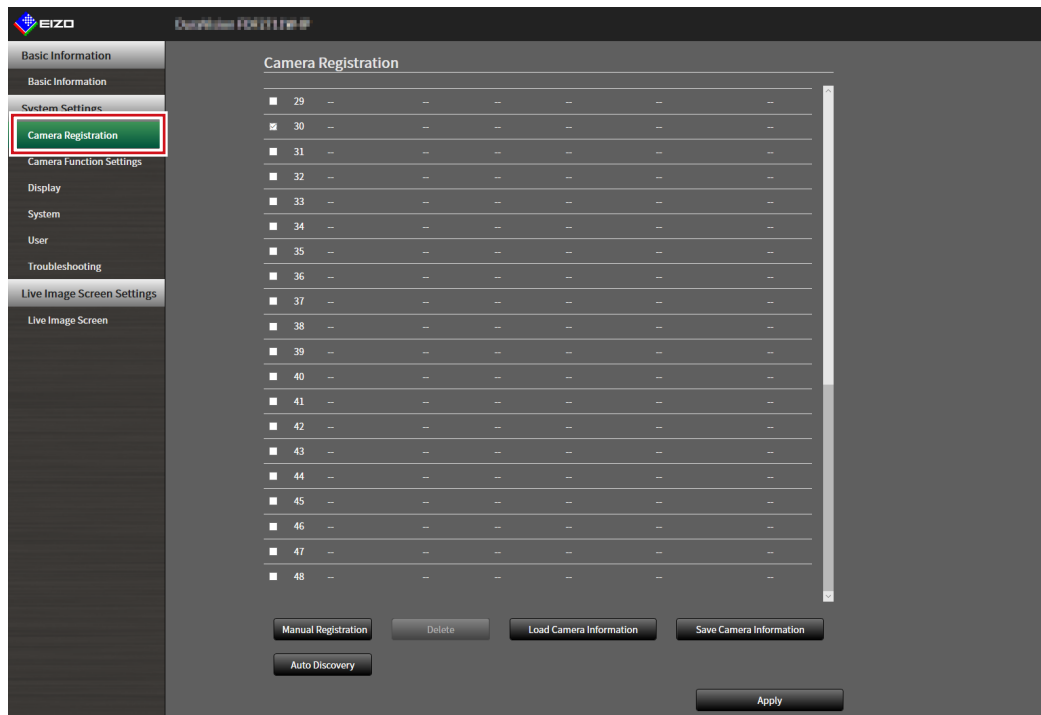

### 2. Select “Save Camera Information”.

A CSV file containing the camera information displayed in the information list is exported.

### Note

- Saved file name: dx0211-ip\_CameraInfo\_yyyymmdd.csv (The date and time of the product is yyyymmdd.)

## 4-6. Importing Network Camera Information

A CSV file that contains additional camera candidates can be imported and used for registration.

### Attention

- This function can be used only when using the web browser.

### 1. Select “Camera Registration”.

A screen is displayed to show a list of camera registration information.

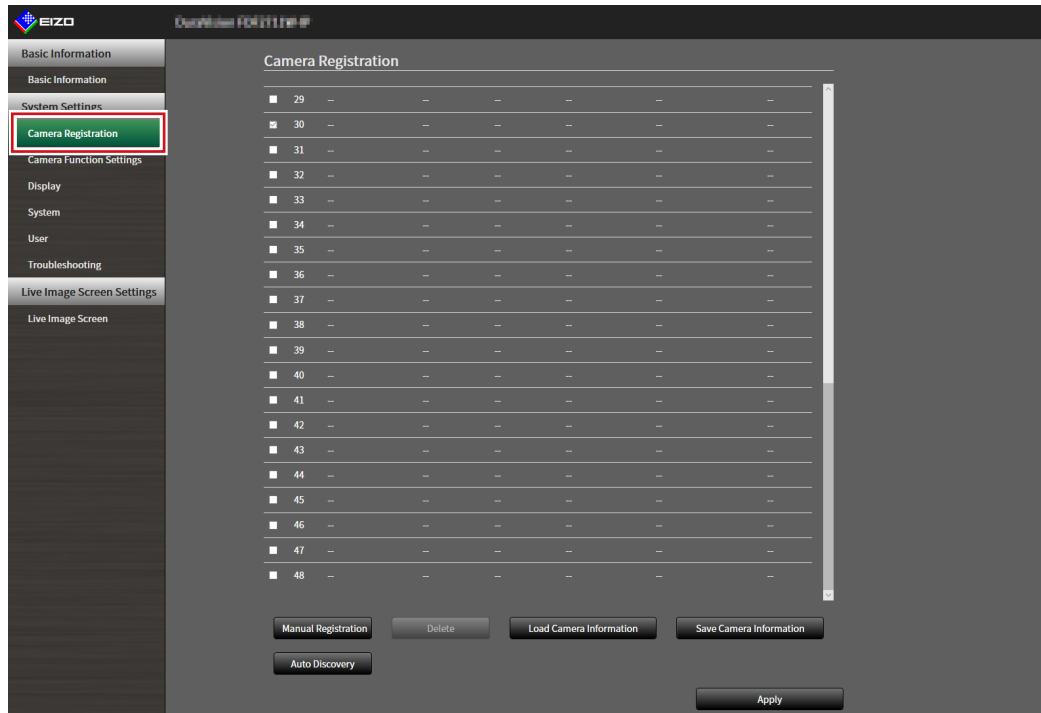

### 2. Select “Load Camera Information”.

A file selection dialog box opens.

### 3. Select the CSV file that contains the network camera information and select “Open”.

A list of the candidate network cameras appears.



### 4. Select a camera to be added from the list of candidates and select “Add”.

Returns to the camera registration information list screen in step 1.



## 5. Select “Apply”.

A setting confirmation dialog box is displayed.

## 6. Select “OK”.

---

**Note**

- Up to 255 candidate cameras can be read.
  - The CSV files that can be read are as follows.
    - CSV files exported from the web browser
    - CSV files created by the user
  - For details on how to export CSV files, refer to [“4-5. Exporting Network Camera Information” \(page 47\)](#).
-

## 4-7. Setting Network Camera Time

Adjust the time of the network camera to the time of this product.

### Attention

- Cannot be set if the camera does not support this function.
- Can only be set when “Protocol” is “Panasonic” or “ONVIF” during camera registration.

### 1. Select “Camera Function Settings”.

The “Camera Function Settings” screen is displayed.

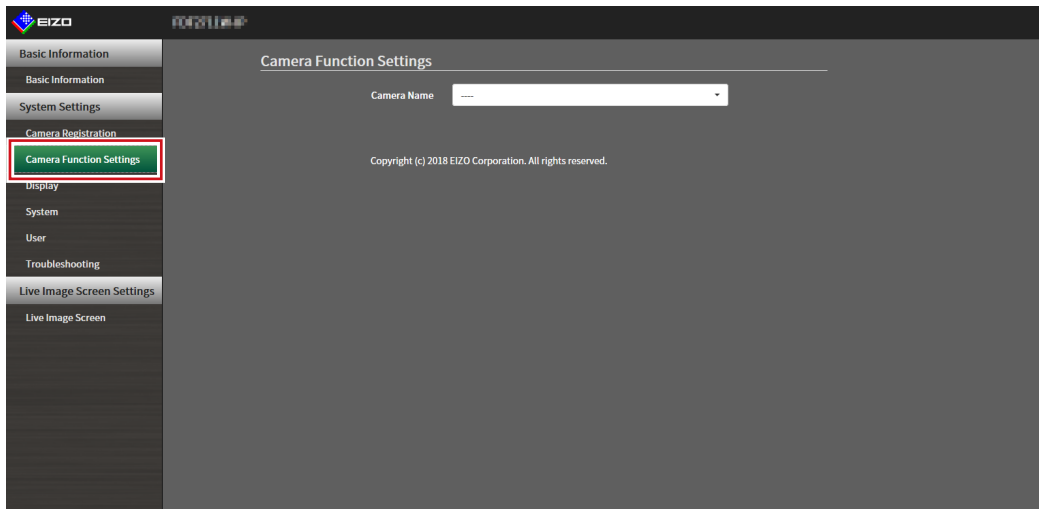

### 2. Select a network camera to be set from “Camera Name”.

Information on the selected network camera is displayed.

### 3. Select “Execute” for “Camera Info. Display/Clock Settings”.

The clock is synchronized.

### Note

- The following settings are possible when “Protocol” of the registered camera is “Panasonic”.
  - Camera Information Display
  - Time Display
  - Display Position

## 4-8. Setting Quality of Transmission Video Images

Set the quality of video images transmitted from the network cameras.

### Note

- This product supports H.264, H.265 (Panasonic only), and MJPEG video compression formats.

### Attention

- When devices such as recorders are connected to a network camera, the display and recording of such devices may be affected.
- Setting cannot be performed if “Protocol” is a “DirectUri” network camera.

### 1. Select “Camera Function Settings”.

The “Camera Function Settings” screen is displayed.

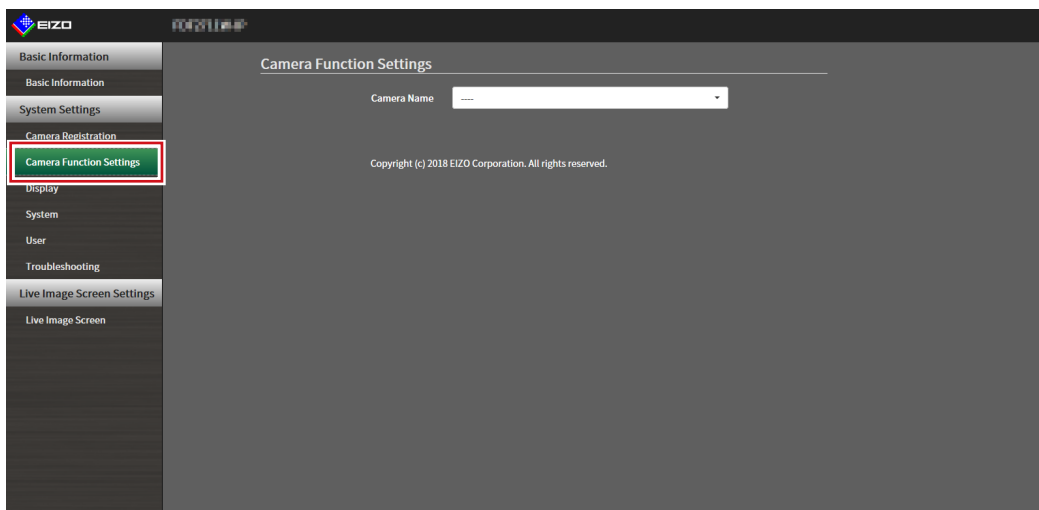

### 2. Select a network camera to be set from “Camera Name”.

Information on the selected network camera is displayed.

### 3. Set the following items under “Video Settings”.

Protocol			Item	Detail	Setting range
Panasonic	AXIS	ONVIF			
		√	Media Profile	Select the profile.	EIZO_Profile / Profile of each camera
		√	Encoder	Select the encoder settings.	According to the camera specifications
√ <sup>*3</sup>	√	√ <sup>*3</sup>	Compression Format	Select the compression format.	H.264 / H.265 / MJPEG
√ <sup>*3</sup>	√	√	Resolution	Set the resolution.	According to the camera specifications
√ <sup>*4</sup>	√	√	Frame Rate	Set the frame rate (video image update interval).	According to the camera specifications
		√	Encoding Interval	Set the encoder interval.	According to the camera specifications
√	√	√	Bit Rate (Max.)	Set the maximum bit rate.	0 to 8192 kbps
		√	Video Quality	Set the image quality. The higher the value, the higher the image quality.	According to the camera specifications
		√	GOV Length <sup>*1</sup>	Set the I-frame interval.	According to the camera specifications
		√	H.264 Profile <sup>*1</sup>	Select a H.264 standard profile.	Baseline / Main / Extended / High
√ <sup>*3</sup>	√ <sup>*3</sup>	√ <sup>*3</sup>	Comm. Method	The communication methods for camera video images are displayed.	RTP over UDP / RTP over RTSP / SRTP over UDP
√ <sup>*3</sup>	√	√	Transmission Mode	Select the transmission mode.	Unicast / Multicast
√ <sup>*3</sup>	√	√ <sup>*3</sup>	Multicast Address <sup>*2</sup>	Set the Multicast address for Multicast transmission.	224.0.0.0 to 239.255.255.255
√ <sup>*3</sup>	√	√ <sup>*3</sup>	Multicast Port <sup>*2</sup>	Set the Multicast port number for Multicast transmission.	1824 to 65534: even numbers only
√ <sup>*3</sup>	√	√ <sup>*3</sup>	Multicast TTL <sup>*2</sup>	Set the network TTL value for Multicast transmission.	According to the camera specifications
√			Refresh Interval	Set the refresh interval (I-frame interval) of images.	0.2 to 5 seconds
√			Transmission Priority	Set the video bit rate transmission priority.	Constant Bit Rate / Frame Rate / Best Effort
√ <sup>*5</sup>			Bit Rate (Min.)	Set the minimum bit rate for the video to be transferred.	0 to 8192 kbps
√ <sup>*6</sup>			Image Quality	Set the image quality for the video to be transferred.	Fine (prioritize image quality) / Normal / Low (prioritize motion)
	√		Video Stream	Select the display mode to be used by the camera display.	According to the camera specifications
	√		Stream Profile	Select the profile that the camera has.	EIZO_Profile / Profile of each camera
	√ <sup>*3</sup>		Rotation	Select the rotation direction of the images.	0 / 90 / 180 / 270
	√ <sup>*3</sup>		GOP Length <sup>*1</sup>	Select the GOP length for the video.	According to the camera specifications
	√		Priority <sup>*1</sup>	Sets the priority for video compression.	None / Frame Rate / Quality

- \*1 Displayed when “H.264” is selected for “Compression Format”.
- \*2 Displayed when “Multicast” is selected for “Transmission Mode”.
- \*3 Read Only
- \*4 Can only be adjusted when “Transmission Priority” is “Frame Rate”
- \*5 Can only be adjusted when “Transmission Priority” is “Best Effort”
- \*6 Can only be adjusted when “Transmission Priority” is other than “Frame Rate”

---

**Note**

- If “Protocol” of the network camera is set to “DirectUri”, setting contents are displayed.
  - The following settings are possible in “Other” when “Protocol” is “Panasonic” during camera registration.
    - Pan/Tilt-flip
    - Upside-down
    - Lamp Display
- 

## 4. Select “Apply”.

The setting complete screen is displayed.

## 5. Select “OK”.

---

**Attention**

- Depending on the network camera, some set values may not be reflected. Check the specifications of the camera.
  - When changes are made to image quality settings such as resolution, the image quality of other recording devices and display devices using the same “Encoder” may be affected.
  - Check the impact of changes to the image quality settings before configuring the settings.
-

# Chapter 5 Live Image Screen Settings

In the live image screen settings, display settings such as changing the live image screen layout are performed.

## 5-1. Setting Display Positions of Camera Video Images

Set the display position for video images from the network camera.

You can switch the display positions of the source and destination camera images by dragging and dropping the camera name.

**Note**

- It is possible to set all the display positions of the registered network cameras.

### 1. Select “Display Position Settings” of “Display”.

The “Display Position Settings” screen is displayed.

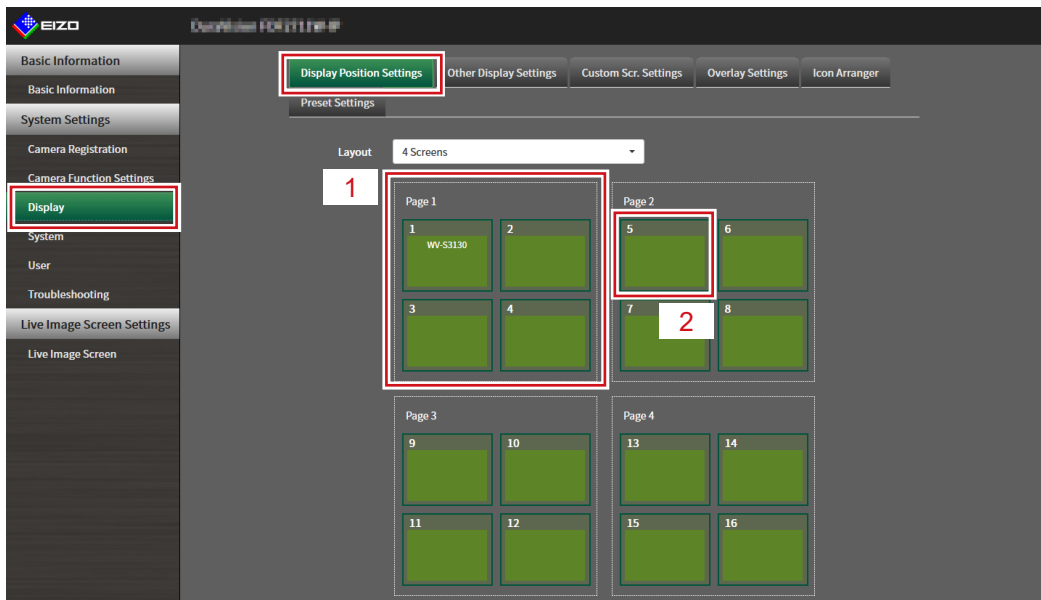

No.	Description
1	A group of cameras displayed at the same time in the video image display area.
2	The position of a camera displayed in the video image display area. The registered camera name is displayed.

## 2. Select the layout of the live image screen.

Select one from the “Layout” list box.

---

**Note**

- When a layout is selected, the display on the page changes to the selected state. You can set the layout while imagining the display status.
  - The initial display position when the screen is transitioned is the display position currently set for this product.
- 

## 3. Select the name of the camera to move, and drag and drop the name on the position of the destination camera name.

The display positions of the source and destination camera video image are switched.

### **Example: 4-screen layout**

1. Select “Display Position 1” for page 1.

2. Drag and drop it at “Display Position 5” on page 2.

The “Display Position 1” camera and “Display Position 5” camera are switched.

Only the camera name in the inner square is moved. The display position of the camera video image does not move.

## 4. Select “Apply”.

The display positions of camera video images are updated. When “Reset” is selected, the information of the setting being changed is discarded and the setting is reset to the current display setting of the product.

---

**Note**

- If displayed on the web browser screen, a camera web page link is embedded in the frame where a camera name is assigned. (Excluding network cameras with their “Protocol” set to “DirectUri”.)  
Click the camera name, and a camera web page is displayed in a separate window.
-

## 5-2. Setting Display Methods of Camera Video Images

Perform settings for whether to display or hide the camera name, specifying the screen switching interval, and aspect ratio.

### 1. Select “Other Display Settings” of “Display”.

The “Other Display Settings” screen is displayed.

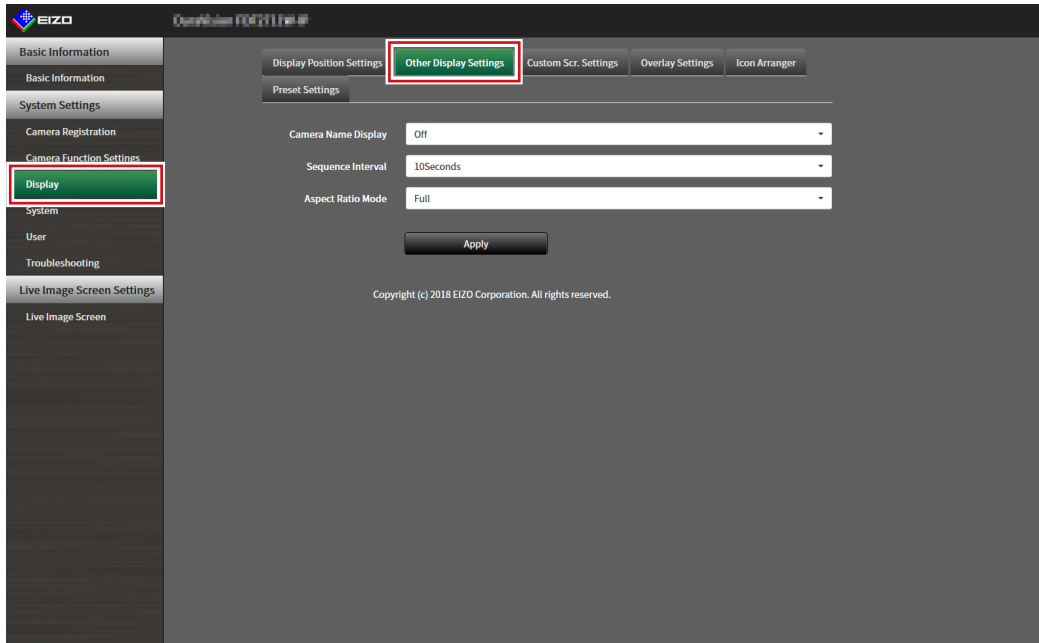

### 2. Set the following items.

Item	Detail	Setting range
Camera Name Display	Select to display or hide the registered camera name on the live image screen. (The camera name is displayed at the upper left of the video image.)	On / Off
Sequence Interval	Set the interval for changing over the screen during sequential display.	5 to 60 seconds
Aspect Ratio Mode	Set which aspect ratio to apply when the aspect ratio of the video image delivered from the network camera is different from the aspect ratio displayed in the image display area on the monitor. If “Aspect” is selected when “Custom Screen” is selected for “Layout”, either “Full” or “Aspect” can be selected for each camera video image. For details, refer to <a href="#">“5-3. Setting Custom Screen Layouts” (page 57)</a> .	Full / Aspect

### 3. Select “Apply”.

The setting complete screen is displayed.

### 4. Select “OK”.



## 5-3. Setting Custom Screen Layouts

Set the display layout when “Custom Screen” is selected in “Layout” for the Live Image Screen.

### 1. Select “Custom Scr. Settings” of “Display”.

The “Custom Scr. Settings” screen is displayed.

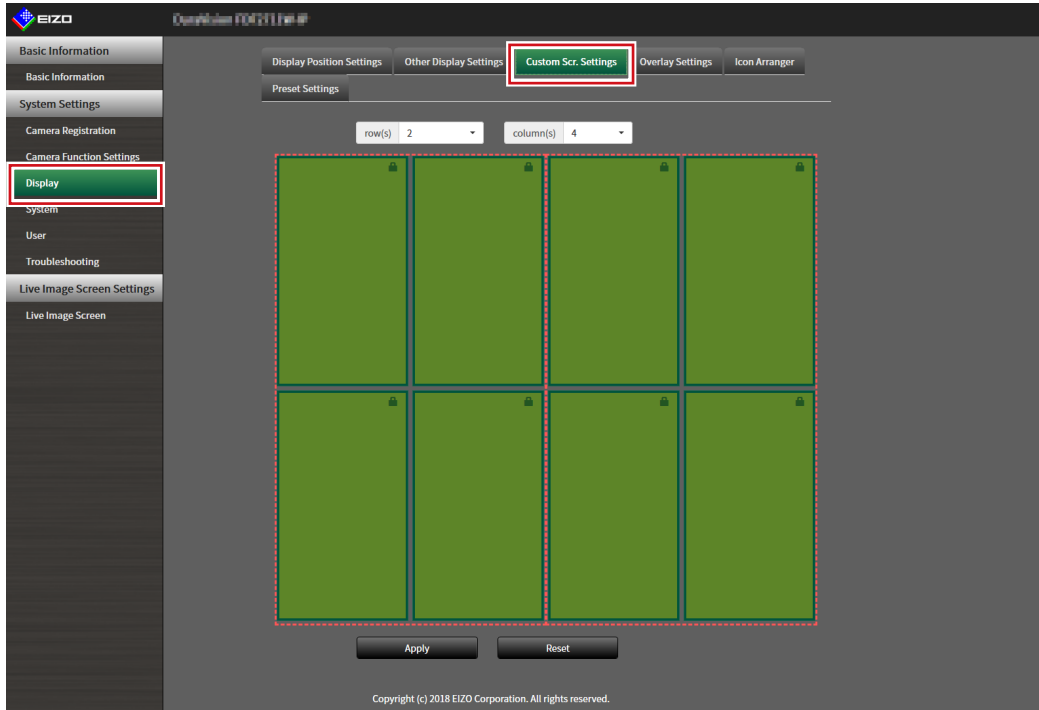

#### Note

- When set to “Extended” in “Multi-Monitor”, the range displayed on each monitor is shown as a red, dotted line.
- Click  in the display position frame to fix the display position of any camera image. The display position for the specified camera image is maintained even if the pages are switched. This function can only be used with “Custom Scr. Settings”.

### 2. Select the number of “row(s)” and “column(s)” from the list box.

The screen will change to a layout with the selected number of columns and rows.

### 3. Drag a camera image display position and drop it on the display position you want to couple with.

The selected display position is coupled.

### 4. Select “Apply”.

The display position coupling is updated. When “Reset” is selected, the information of the setting being changed is discarded and the setting is reset to the current display setting of the product.

#### Note

- To release the coupling, click the display position just coupled. This can also be performed by changing the number of columns and rows from the list box.
- If “Aspect Ratio Mode” is set to “Aspect”, “Full” or “Aspect” is displayed for the camera display position, and the setting changes every time either one of them is selected.
- For information on setting “Aspect Ratio Mode”, see [“5-1. Setting Display Positions of Camera Video Images” \(page 54\)](#).

## 5-4. Changing the Displayed Layout Icon

You can change the icons to be displayed on the display menu on the live image screen.

### Attention

- This function can only be used with the “Enterprise” software edition. For more information regarding software editions, see “3-10. Performing License Activation” (page 25).

### 1. Select “Icon Arranger” in “Display”.



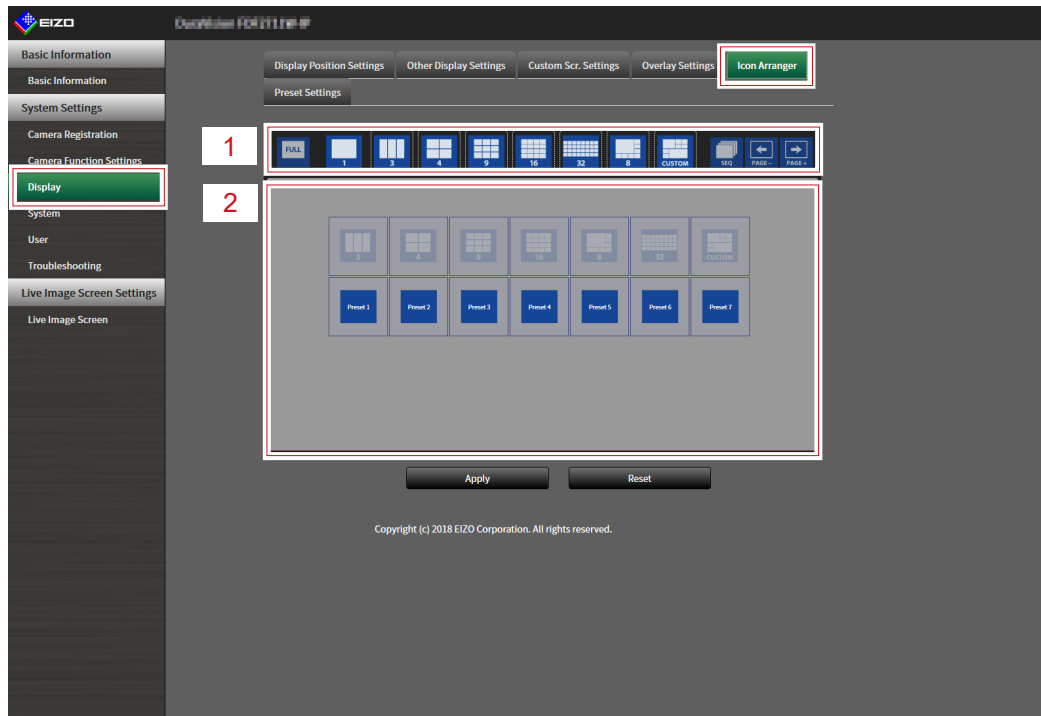

The “Icon Arranger” screen is displayed.



No.	Description
1	Icon Registration Area
2	Icon Selection Area

### 2. Drag the icon you wish to change and drop it in the icon registration area where you wish to display it.

#### Note

- If another icon is already registered at the destination, the position of the icons will switch.
- If you wish to delete an icon from the display menu, drag and drop the icon from the icon registration area to the icon selection area.
- Cannot change     

### 3. Select “Apply”.

## 5-5. Setting Layout Presets

You can save the live image screen display layout and camera location as presets.

### Attention

- This function can only be used with the “Enterprise” software edition. For more information regarding software editions, see [“3-10. Performing License Activation” \(page 25\)](#).

### NOTE

- Up to seven presets can be saved.

### 1. Select “Preset Settings” in “Display”.

The “Preset Settings” screen is displayed.

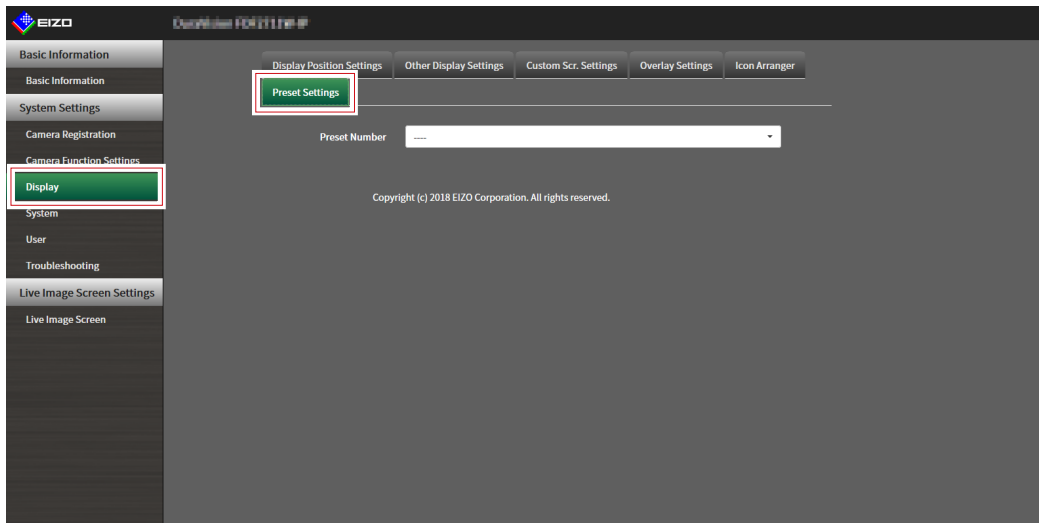

### 2. Select a preset number for configuration from “Preset Number”.

The preset settings screen of the selected preset is displayed.

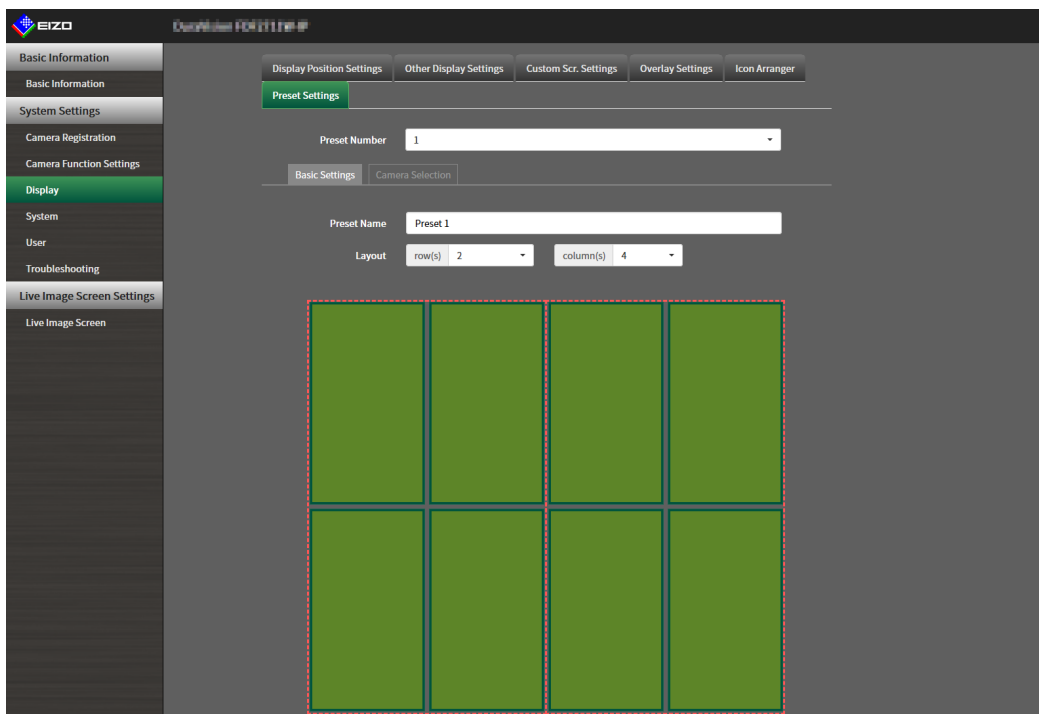

### 3. Set the preset name in “Preset Name” in the “Basic Settings” tab.

Item	Description	Range
Preset name	Enter the preset name.	Alphanumeric numbers, Japanese alphabet*1.Chinese characters*1(up to 16 characters)

\*1 This can be set only when displayed on the web browser.

### 4. Select the number of “Row(s)” or “Column(s)” from the list box.

The screen will change to a layout with the selected number of columns and rows.

### 5. Select the camera image display position and drag and drop it on the display position you want to couple with.

The selected display position is coupled.

#### Note

- Click the coupled display position to deactivate it. Or, change the row(s) and column(s) in the list box.

### 6. Select “Apply”.

### 7. Select the “Camera Selection” tab.

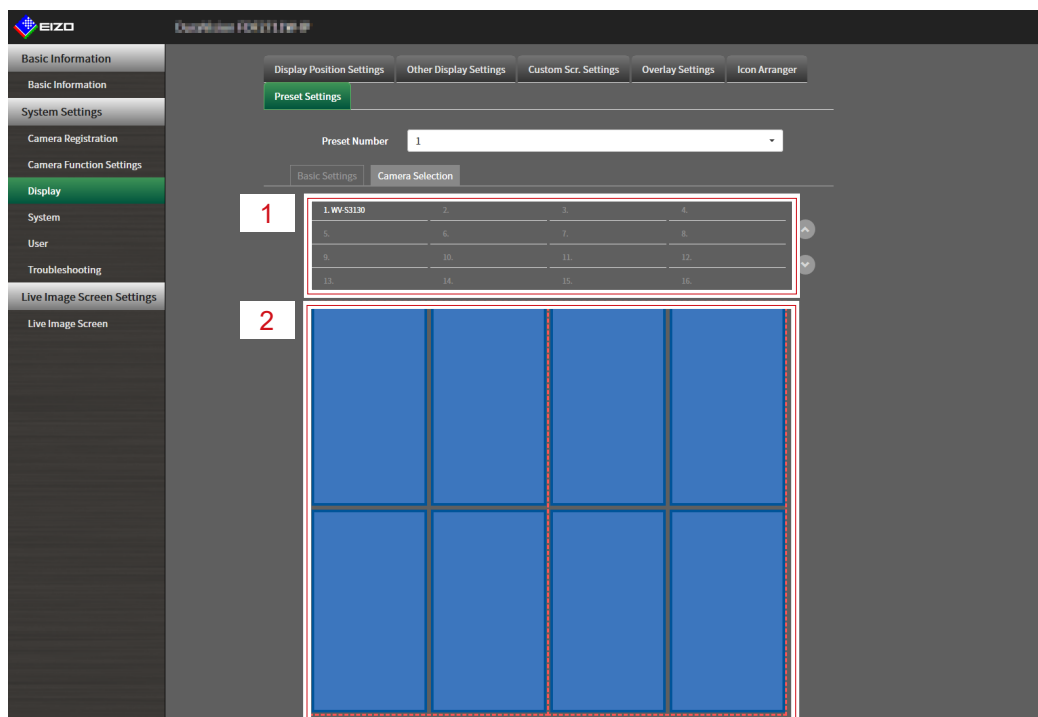

No.	Description
1	Camera Selection Area
2	Camera Location Area

**8. Drag a camera to be set from the camera selection area or camera location area and drop it in the desired location in the camera location area.**

---

**Note**

- Click a camera to be set from the camera selection area to put it in an open position in the camera location area.
  - If another camera is already registered at the destination, the position of the cameras will switch.
  - To deactivate a setting, drag and drop it from the camera location area to the camera selection area.
- 

**9. Select “Apply”.**

## 5-6. Setting the Overlay

It is possible to display privacy masks or virtual lines on camera images on the live image screen.

### 1. Select “Overlay Settings” in “Display”.

The “Overlay Settings” screen is displayed.

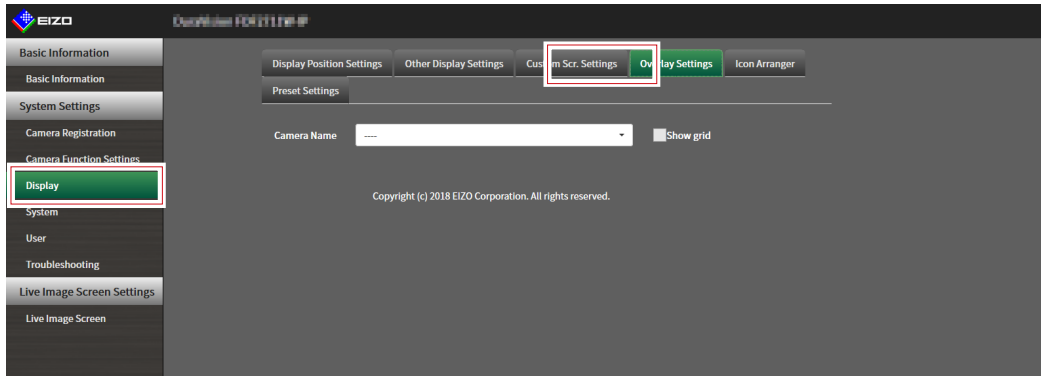

### 2. Select a network camera to be set from “Camera Name”.

The camera settings screen of the selected network camera is displayed.

#### Note

- Check “Show grid” to display a grid on the camera images in the live image screen. This function can be set only when displayed on the web browser.
- Network camera images are displayed in the drawing area on the application screen.

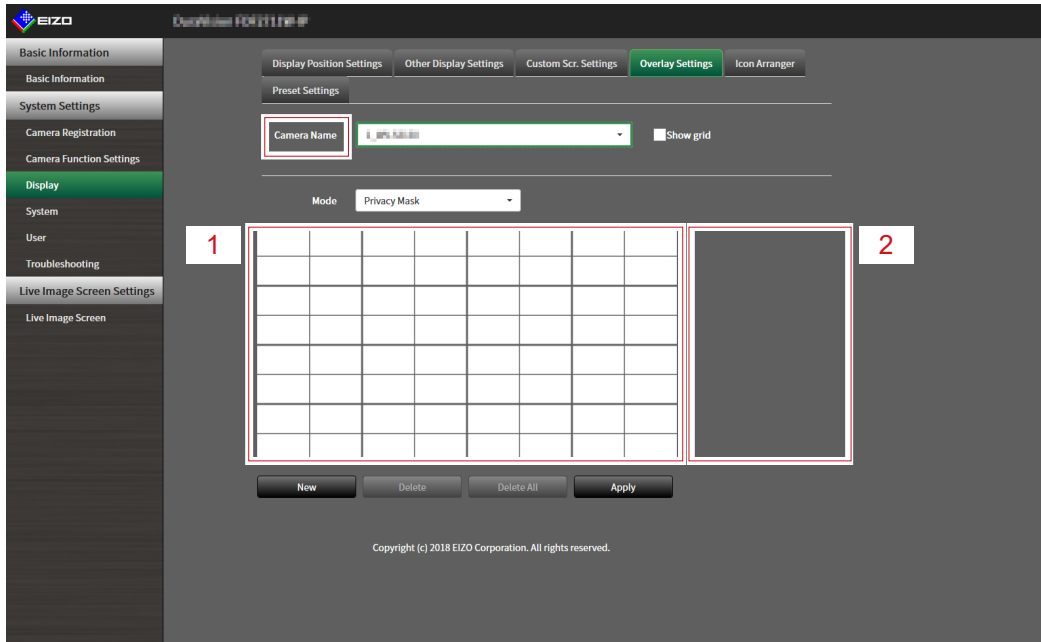

No.	Description
1	Drawing area
2	List area

### 3. Select an overlay type to be set from “Mode”.

Item	Description
Privacy mask	Up to 10 privacy masks can be set. Designates 3 or 4 points in the drawing area and draws polygonal shaped privacy masks.
Virtual line	Up to 10 virtual lines can be set. Designates 2-10 points in the drawing area and draws virtual lines.

### 4. Select “New”.

A new overlay type is added to the list area.

### 5. Set the overlay items

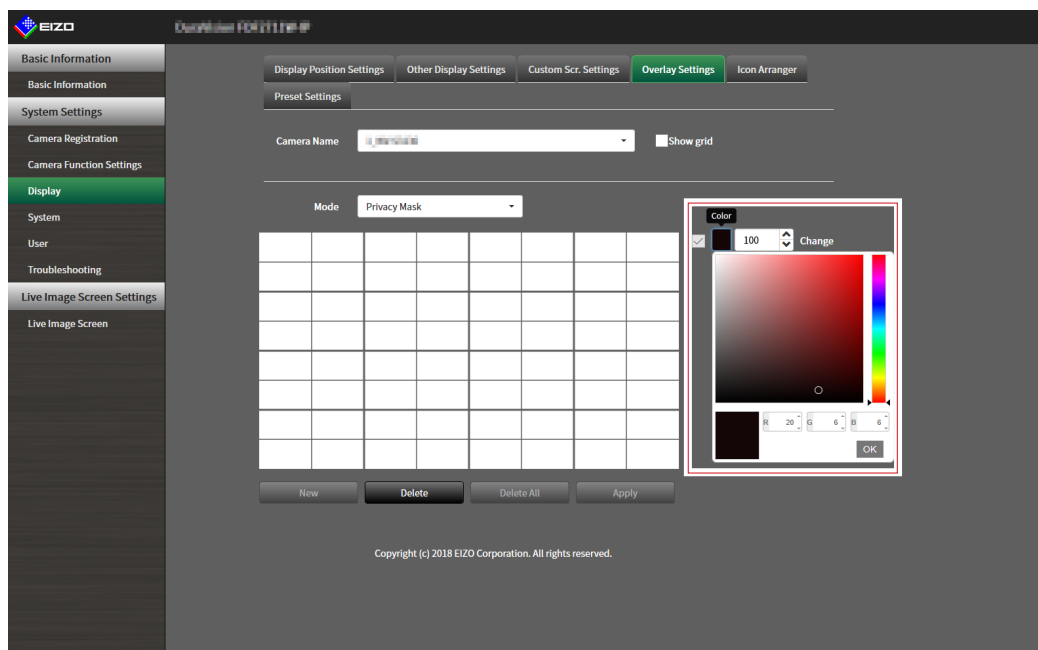

Item	Description	Range
Check box	Switches between displaying/hiding the overlay.	-
Color	Select a color from the color palette.	-
Opacity <sup>*1</sup>	Select opacity.	0 to 100
Weight <sup>*2</sup>	Select line weight	1 to 12
*1 Privacy mask only item.		
*2 Virtual line only item.		

### 6. Draw the overlay in the drawing area.

### 7. Select “Apply”.

The overlay is displayed in the drawing area.

#### Note

- Specific overlays can be deleted by following the steps below.
  1. In the drawing area, select the overlay you wish to delete.  
“Selected” will be displayed on the selected overlay items in the list area.
  2. Select “Delete”.
  3. Select “Apply”.
- Select “Delete All” to delete all overlays..

## 5-7. Setting the Display Methods of Live Image Screens

Display settings such as changing the live image screen layout are performed.

### 1. Select “Live Image Screen Settings” of “Live Image Screen”.

The “Live Image Screen Settings” screen is displayed.

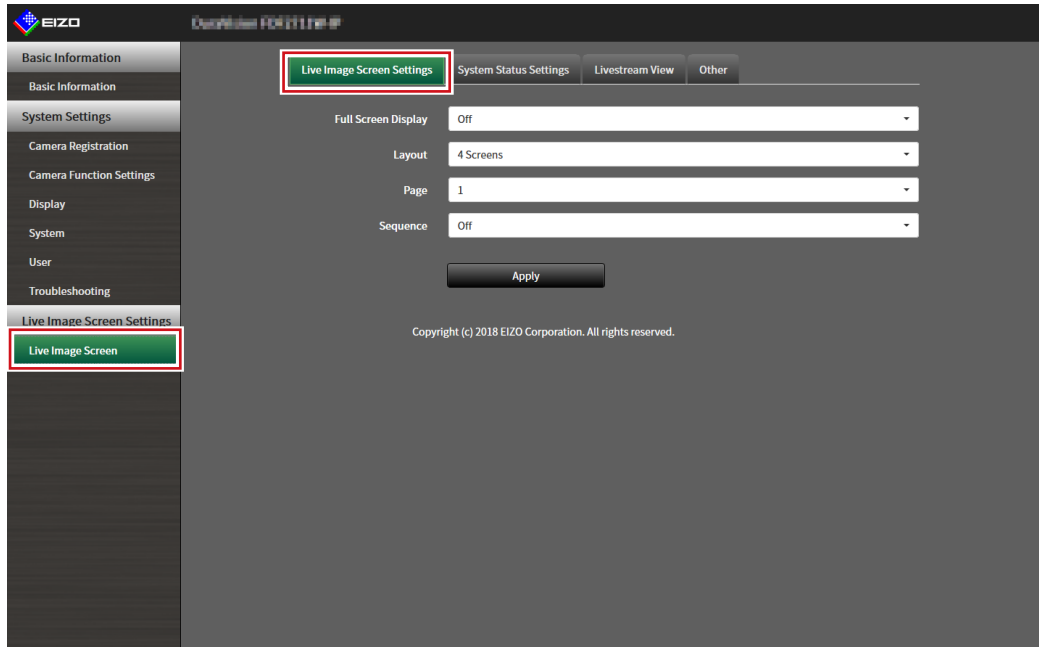

### 2. Select each setting item from the list box.

Item	Detail	Setting range
Full Screen Display	Set to display or hide the menu on the live image screen.	On / Off
Layout	Set the layout to be displayed on the live image screen.	1 Screen / 3 Screens / 4 Screens / 9 Screens / 16 Screens / 32 Screens / 8 Screens / Custom Screen
Page	Set to switch the page of camera video images to display on the monitor.	1 to 48
Sequence	Set to switch the page sequence display on or off.	On / Off

### 3. Select “Apply”.

The setting complete screen is displayed.

### 4. Select “OK”.



## 5-8. Setting Current Monitor Display Status

### 1. Select “System Status Settings” of “Live Image Screen”.

The “System Status Settings” screen is displayed.

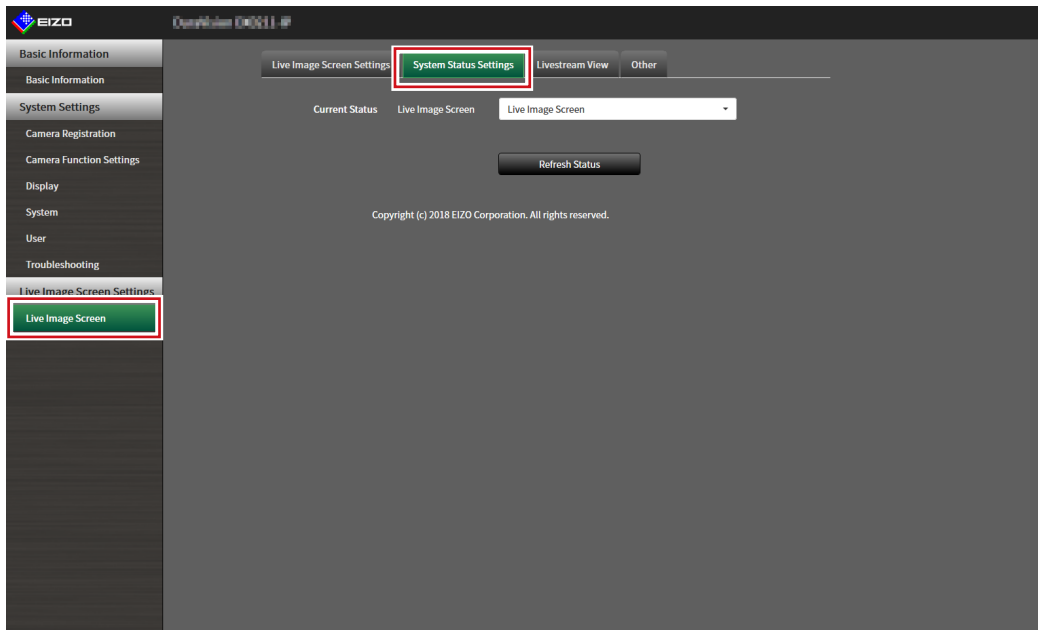

### 2. Click ▼ next to “Current Status” to select the status from the displayed list.

Item	Detail
Live Image Screen	The monitor screen shows the Live Image Screen
Quick Shutdown	The power is off
Setting Screen	The monitor screen displays the Setting Screen
	<b>Attention</b> <ul style="list-style-type: none"><li>It is not possible to change "Current Status" in the "Setting Screen". It is possible to change to other statuses from the "Setting Screen".</li></ul>

#### Note

- Click “Refresh Status” to obtain the current status of the monitor.
- Only “Refresh Status” is displayed on the application screen.

## 5-9. Checking Livestream View

The current live image screen display can be checked by video from the web browser.

### Attention

- This function can only be used with the „Enterprise“ software edition. For more information regarding software editions, see [“3-10. Performing License Activation“ \(page 25\)](#).
- This function can be used by up to two users simultaneously.

### 1. Select „Livestream View“ on the „Live Image Screen“.

The live image screen is displayed as a video. Click „Pause“ to pause the video, and „Resume“ to resume the video. You can switch to full screen display by double clicking the livestream view display.

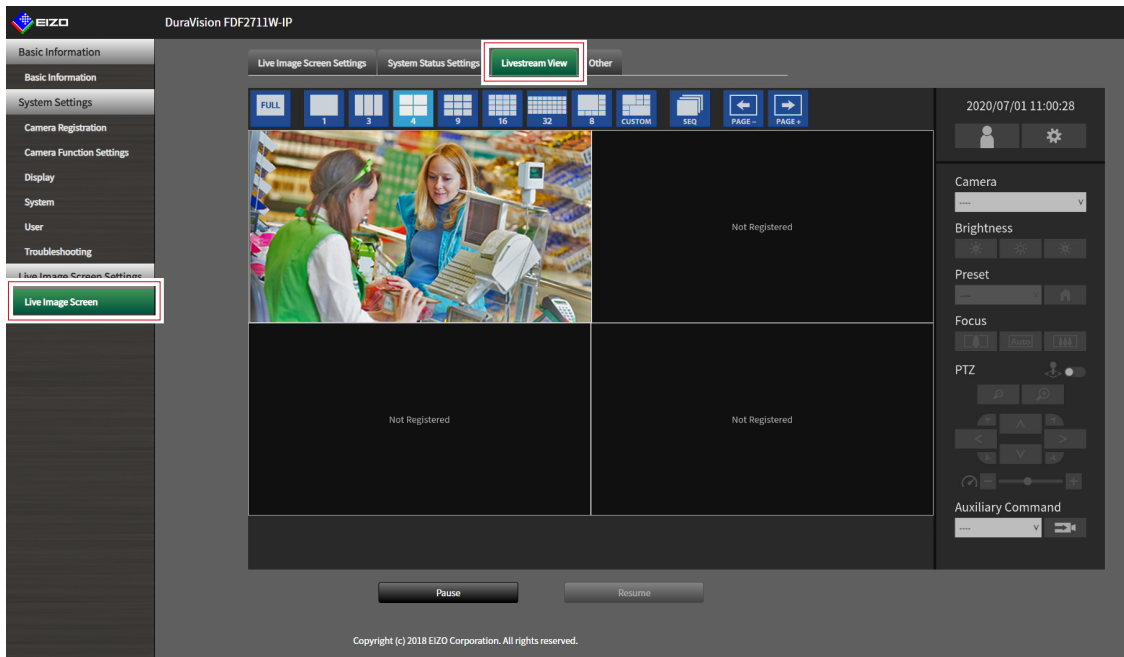

## 5-10. Refreshing the Livestream View

Refresh the status of the livestream view display.

### 1. Select „Other“ on the „Live Image Screen“.

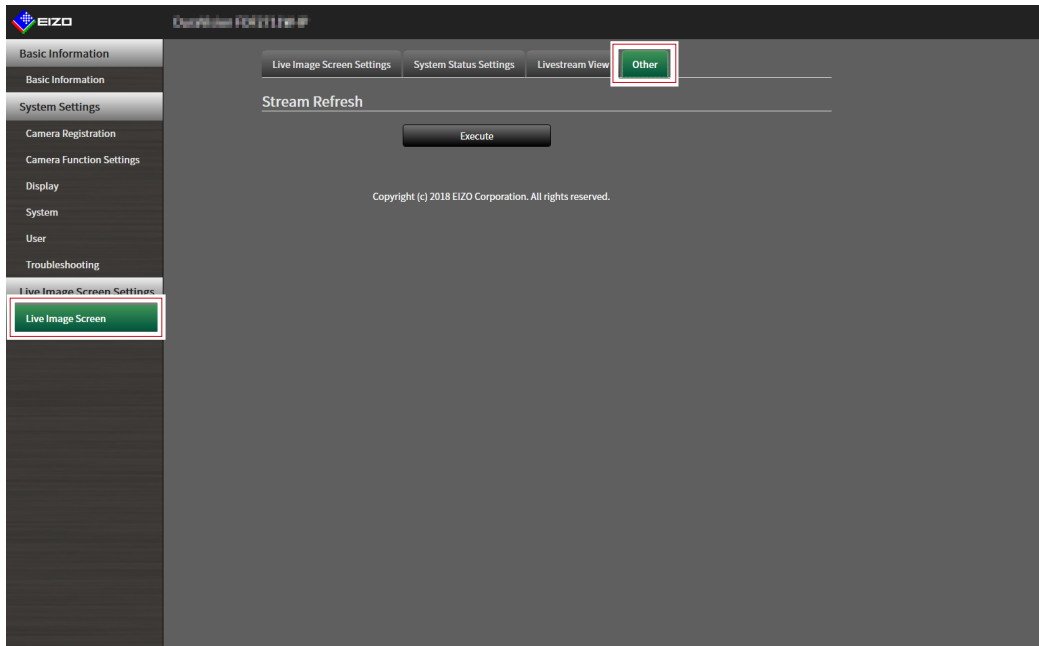

### 2. Select „Execute“.

# Chapter 6 Management of the User Account

Perform procedures such as registering, changing, and deleting user accounts (username, user level, and password) used to access the system, and for configuring Auto Login settings.

## Attention

- A maximum of ten persons can be registered for the user account. User information for a new user cannot be registered when there are already 10 users registered.
- A username that is the same as an already registered user account cannot be registered.
- It is necessary to register at least one user with a user level of "ADMIN".

## Note

- User levels include "LIVE", "CAMERA CONTROL", and "ADMIN".  
The operable range of this product differs by each level.

(√: Operable, -: Inoperable)

Level \ Operation	Menu display	Layout change	Page change	Login operation	System settings
LIVE	√	√	√	√	-
CAMERA CONTROL	√	√	√	√	-
ADMIN	√	√	√	√	√

- The default settings of the user account are as follows.
  - Username: "admin"
  - Password: "admin"
  - User Level: "ADMIN"

## 6-1. Registering the User Account

### 1. Select "Local User" of "User".

The "Local User" screen is displayed.

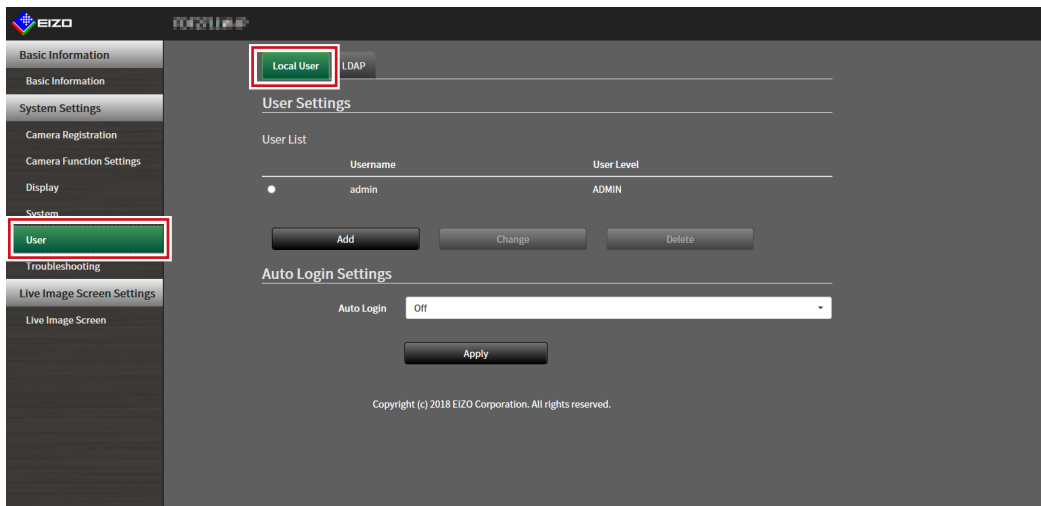

## 2. Select “Add”.

A dialog box for setting the user account is displayed.

Username

User Level

Password

Confirm Password

Your username must satisfy the following conditions:

- 1-16 characters
- Contain alphanumeric characters only
- May not contain the following characters: # & : " < > \

Your password must satisfy the following conditions:

- 8-16 characters
- At least one number
- At least one upper case and one lower case letter
- Contain no \ characters

OK Cancel

## 3. Set the user account.

Item	Description
Username	Enter a username. The username must satisfy the following conditions. <ul style="list-style-type: none"><li>• 8-16 characters</li><li>• Contain alphanumeric characters only</li><li>• May not contain the following characters: # &amp; : " &lt; &gt; \</li></ul>
User Level	Select “LIVE”, “CAMERA CONTROL”, and “ADMIN”. The operable range of this product differs by each level.
Password	Specify the password. The password must satisfy the following conditions. <ul style="list-style-type: none"><li>• 8-16 characters</li><li>• At least one number</li><li>• At least one upper case and one lower case letter</li><li>• Contain no \ characters</li></ul>
Confirm Password	Enter the same password again for confirmation.

## 4. Select “OK”.

The setting complete screen is displayed.

## 5. Select “OK”.

## 6-2. Changing the User Account

### Attention

- This function cannot be used if “LDAP” is selected in “User Account”. For details, refer to “6-5. Performing LDAP Settings” (page 73).

### 1. Select “Local User” of “User”.

The “Local User” screen is displayed.

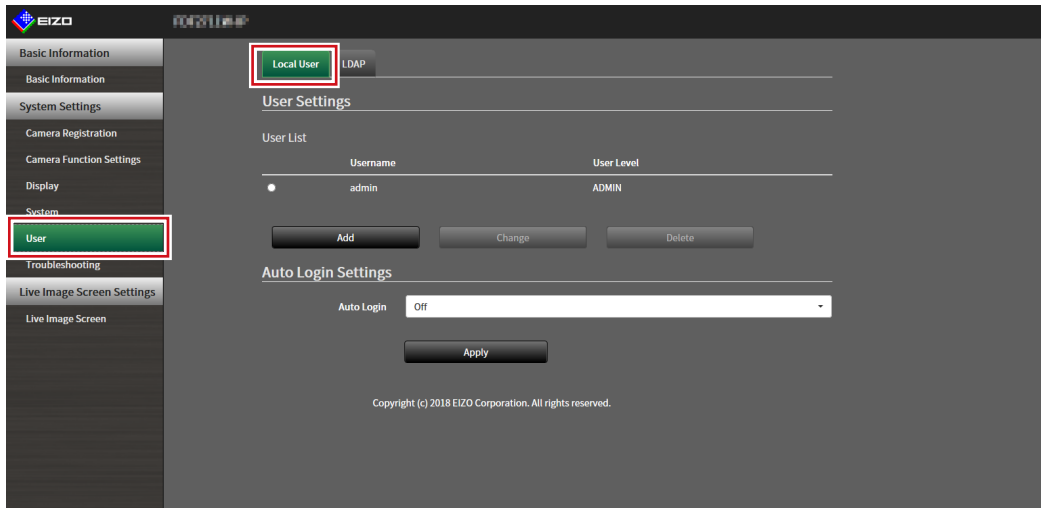

### 2. Select a user to be changed from “User List”.

### 3. Select “Change”.

A dialog box for entering the user information is displayed.

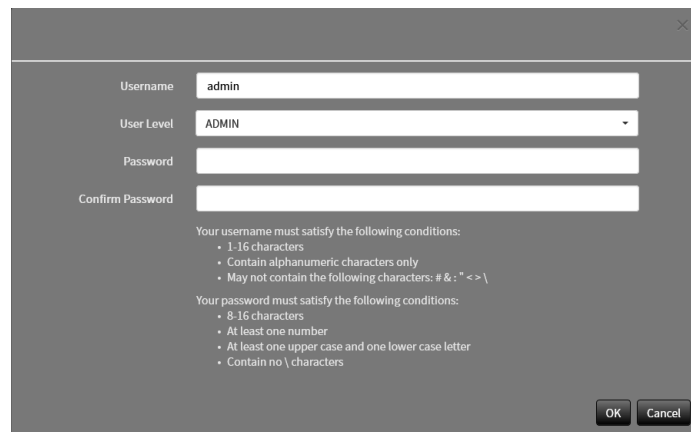

Username

User Level

Password

Confirm Password

Your username must satisfy the following conditions:

- 1-16 characters
- Contain alphanumeric characters only
- May not contain the following characters: # & : " < > \

Your password must satisfy the following conditions:

- 8-16 characters
- At least one number
- At least one upper case and one lower case letter
- Contain no \ characters

OK Cancel

### 4. Change the user information.

### 5. Select “OK”.

The setting complete screen is displayed.

### 6. Select “OK”.

## 6-3. Deleting the User Account

### Attention

- This function cannot be used if “LDAP” is selected in “User Account”. For details, refer to [“6-5. Performing LDAP Settings”](#) (page 73).

### 1. Select “Local User” of “User”.

The “Local User” screen is displayed.

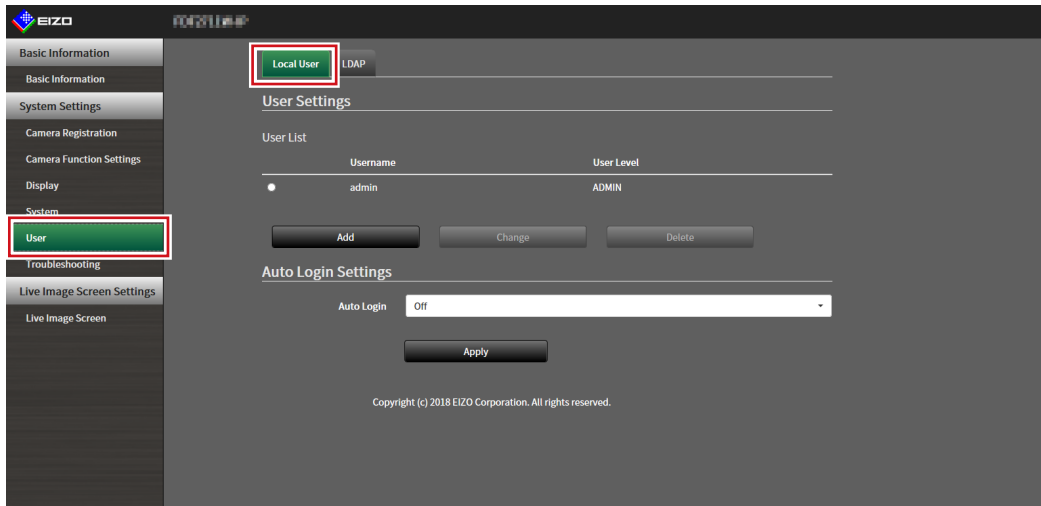

### 2. Select a user to be deleted from “User List”.

### 3. Select “Delete”.

The “Are you sure you want to delete user XXX?” confirmation dialog box is displayed.

### 4. Select “OK”.

When not deleting, select “Cancel”.

The “Setting Complete” dialog box is displayed.

### 5. Select “OK”.

## 6-4. Configuring Auto Login Settings

### Attention

- This function cannot be used if “LDAP” is selected in “User Account”. For details, refer to [“6-5. Performing LDAP Settings”](#) (page 73).
- Once the Auto Login settings are configured, unauthorized operation becomes easy for a malicious third party. Restrict the configuration to the application in an environment where sufficient security is ensured.

### 1. Select “Local User” of “User”.

The “Local User” screen is displayed.

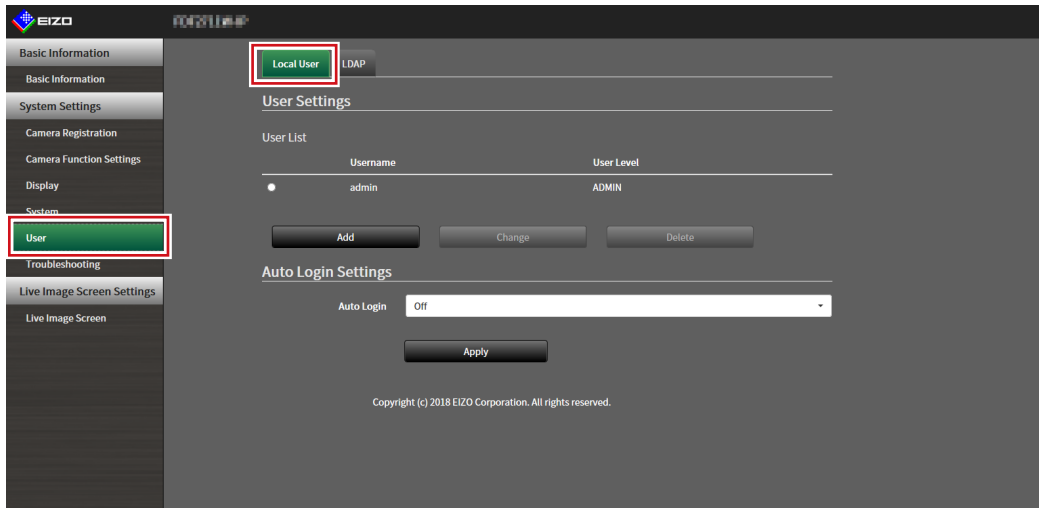

### 2. Select a user to allow an Auto Login from the “Auto Login” list box.

### 3. Select “Apply”.

The setting complete screen is displayed.

### 4. Select “OK”.



## 6-5. Performing LDAP Settings

It is possible to log in to this product using a user account on the LDAP server when using direct service (LDAP) in User Management.

### Attention

- This function can only be used when the software edition is “Enterprise”. For information on software editions, refer to [“3-10. Performing License Activation” \(page 25\)](#).
- If “User Account” is set to “LDAP”, it is not possible to login as a local user.
- Access via web browser is only possible when the user level of the account is ADMIN.
- It is not possible to login to this product if the LDAP settings are incorrect. For this reason, perform a login test to confirm that it is possible to login with a user account with the ADMIN user level before applying the LDAP settings.

### 1. Select “LDAP” of “User”.

The “LDAP” screen is displayed.

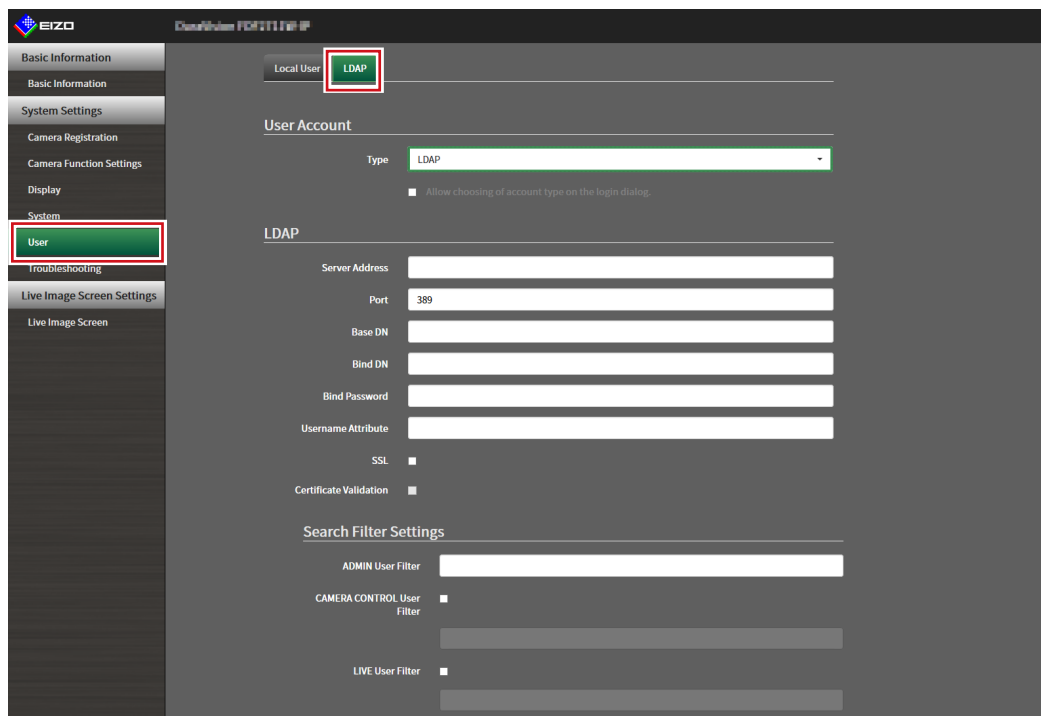

The screenshot shows the EZO User Management web interface. On the left is a navigation menu with categories: Basic Information, System Settings, Camera Registration, Camera Function Settings, Display, System, User (highlighted with a red box), Troubleshooting, Live Image Screen Settings, and Live Image Screen. The main content area is titled 'Local User' and 'LDAP'. Under 'Local User', there is a 'User Account' section with a 'Type' dropdown menu set to 'LDAP' (highlighted with a red box). Below this is a checkbox for 'Allow choosing of account type on the login dialog.'. The 'LDAP' section contains several input fields: 'Server Address', 'Port' (set to 389), 'Base DN', 'Bind DN', 'Bind Password', and 'Username Attribute'. There are also checkboxes for 'SSL' and 'Certificate Validation'. The 'Search Filter Settings' section includes 'ADMIN User Filter' (with an input field), 'CAMERA CONTROL User Filter' (with a checkbox), and 'LIVE User Filter' (with a checkbox).

### 2. Select “LDAP” from “Type” of “User Account”.

#### Note

- Checking “Allow choosing of account type on the login dialog.” enables selecting account type when logging into the product main unit.

### 3. Perform LDAP settings.

#### LDAP

Item	Detail	Setting range
Server Address	Enter the IP address or host name of the LDAP server.	Alphanumerics and symbols (up to 255 characters)
Port	Enter the port number.	1 to 65535*1
Base DN	Enter the identification name of the branch to search. Ex: ou=ldap,dc=example,dc=com	Alphanumerics and symbols (up to 255 characters)
Bind DN	Enter the username that has access rights to Base DN. Ex: cn=binduser,ou=ldap,dc=example,dc=com	Alphanumerics and symbols (up to 255 characters)
Bind Password	Enter the Bind DN password.	Alphanumerics and symbols (up to 255 characters)
Username Attribute	Enter the attributes of the user account to login. Ex: cn	Alphanumerics and symbols (up to 255 characters)
SSL	Insert a check when performing SSL communication (LDAPS).	
Certificate Validation	Insert a check when performing certificate validation. <b>Attention</b> <ul style="list-style-type: none"><li>When performing certificate validation, it is necessary for the root certificate of the LDAP server to be registered in "Root Certificate" of "Certificate" of this product.</li></ul>	

\*1 389 is the standard port number for LDAP, and 636 is the standard port number for LDAPS.

#### Search Filter Settings

Item	Detail	Setting range
ADMIN User Filter	Set the filter of the user that has ADMIN access rights. Example: (memberOf=cn=admin,ou=ldap,dc=example,dc=com)	Alphanumerics and symbols (up to 255 characters)
CAMERA CONTROL User Filter	To enable camera control access rights, enter a check to set the filter.	
LIVE User Filter	To enable LIVE access rights, enter a check to set the filter.	

### 4. Perform "Login Test".

Enter "Username" and "Password", and select "Test".

Login is executed.

### 5. Select "Apply".

# Chapter 7 Troubleshooting

## 7-1. Imaging Problems

Problem	Possible cause and remedy
<b>1. The screen is not displayed on the monitor</b>	<ul style="list-style-type: none"><li>• Check that the power supply to the monitor is turned on.</li><li>• Is the HDMI cable correctly connected? Is the input signal on the monitor set to the HDMI input?</li></ul>
<b>2. The display images are not smooth / camera images are not displayed</b>	<ul style="list-style-type: none"><li>• Reduce the resolution and/or bit rate set for the network camera. (Refer to <a href="#">“4-8. Setting Quality of Transmission Video Images”</a> (page 51).)</li><li>• Check whether the used hubs and network cables are appropriate for handling the amount of information transmitted.</li><li>• Move to the setting screen and return to the live image screen.</li></ul>
<b>3. The camera images are not displayed properly on the live image screen about 30 seconds after turning the power off by pushing  on the main unit of the product.</b>	<ul style="list-style-type: none"><li>• When the main power is turned off and immediately back on, images may not be displayed properly for the first few minutes. After several minutes, the screen returns to a normal display.</li></ul>
<b>4. The time of the network camera and the time of the system do not match (when a camera images are being displayed)</b>	<ul style="list-style-type: none"><li>• On the setting screen, adjust the time of the network camera to match the time of this product. (Refer to <a href="#">“4-7. Setting Network Camera Time”</a> (page 50).)</li></ul>

Problem	Possible cause and remedy
<p><b>5. An error message “E**-***” is displayed on the camera image display area</b></p>	<ul style="list-style-type: none"> <li>• When Communication failed (“E01-***”) <ul style="list-style-type: none"> <li>- A number of devices exceeding the allowable number of devices for simultaneous connection may be connected to the network camera. Disconnect other network devices accessing the camera or reduce the resolution of the camera. (Refer to <a href="#">“4-8. Setting Quality of Transmission Video Images”</a> (page 51).)</li> </ul> </li> <li>• When Communication failed (“E02-***”) <ul style="list-style-type: none"> <li>- Check whether a network cable is connected properly.</li> <li>- Check whether the network camera is turned on.</li> <li>- Check whether the username and password for the camera are set correctly in the system.</li> <li>- Isn't there an IP address conflict among this product and network cameras?</li> <li>- If “Certificate Validation” is enabled, is the certificate expiration date correct? (Refer to <a href="#">“3-12. Performing Certificate Settings”</a> (page 29).)</li> </ul> </li> <li>• When Communication failed (“E03-***”) <ul style="list-style-type: none"> <li>- Network bandwidth may be overwhelmed or the display capability of this product may have been exceeded. Reduce the resolution and/or bit rate set for the network camera. (Refer to <a href="#">“4-8. Setting Quality of Transmission Video Images”</a> (page 51).)</li> </ul> </li> <li>• When in Incompatible resolution (“E04-***”) <ul style="list-style-type: none"> <li>- A resolution which is incompatible with this product may be set. Try changing the resolution of the network camera.</li> </ul> </li> <li>• When Compression format is mismatched (“E05-***”) <ul style="list-style-type: none"> <li>- The streaming format from the network camera may be different from that of this product. Check the settings of the camera and this product and then restart this product.</li> </ul> </li> <li>• When Unapproved parameters (“E06-***”) <ul style="list-style-type: none"> <li>- The Multicast setting value may not be set correctly. Check the settings of the camera.</li> </ul> </li> <li>• If it is a network connection error (E07-**): <ul style="list-style-type: none"> <li>- This product may not be connected to the network, possibly LAN cable is not connected. Check the network connection.</li> </ul> </li> </ul>

## 7-2. Setting Problems

Problem	Possible cause and remedy
1. Cannot log in	<ul style="list-style-type: none"> <li>• Enter the user name and password again.</li> <li>• Reset the account information using the Reset button and log in as the default setting account. (See “Setup Manual”)</li> </ul>
2. Only one camera is recognized when using a video encoder that supports multiple channels	<ul style="list-style-type: none"> <li>• Manually register the number of channels that will be used. (Refer to “4-1. Registering a Network Camera Using Auto Discovery” (page 39).)</li> </ul>
3. A communication error message is displayed when “Apply” is selected for network camera manual registration	<ul style="list-style-type: none"> <li>• There may be a problem with network camera communication. Check the network connection status and camera registration details.</li> </ul>
4. Cannot register a new user	<ul style="list-style-type: none"> <li>• Duplicate user names cannot be registered.</li> <li>• Only up to 10 users can be registered. Check whether 10 users have already been registered. (Refer to “Chapter 6 Management of the User Account” (page 68).)</li> </ul>
5. Cannot delete a user	<ul style="list-style-type: none"> <li>• There must be at least one user with a level of “ADMIN”. A user cannot be deleted if the user is the only one registered with a level of “ADMIN”. Check the registered user information. (Refer to “Chapter 6 Management of the User Account” (page 68).)</li> </ul>
6. Cannot communicate with the camera	<ul style="list-style-type: none"> <li>• Check the settings of the network camera and the system. For details, contact the system administrator.</li> </ul>
7. The set date and time are not displayed correctly	<ul style="list-style-type: none"> <li>• If the system is not connected to the power supply for one week or longer, the date and time will not be displayed correctly. In such a case, set the date and time again. (Refer to “3-3. Setting the Current Date and Time” (page 15).)</li> </ul>
8. Web browser screen cannot be displayed.	<ul style="list-style-type: none"> <li>• Check if there is no conflict of IP addresses for devices on the same network. Connecting multiple units of this product to the same network without changing their default values will result in an IP address conflict. For information on network settings, refer to “3-1. Performing Network Settings” (page 11).</li> </ul>

# List of Functions

Basic Information.....	page 10
System Information	
Camera / Display Position	
Date and Time	
Network	
Communication	
Certificate	
Other	
Event Rules	
Remote Controller	
User Account* <sup>1</sup>	
System Settings	
Camera Registration	
Manual Registration.....	page 41 / page 44
Delete.....	page 46
Save Camera Information* <sup>2</sup> .....	page 47
Load Camera Information* <sup>2</sup> .....	page 48
Auto Discovery.....	page 46
Camera Function Settings.....	page 50 / page 51
Display	
Display Position Settings.....	page 54
Other Display Settings.....	page 56
Custom Scr. Settings.....	page 57
Overlay Settings.....	page 62
Icon Arranger* <sup>1</sup> .....	page 58
Preset Settings* <sup>1</sup> .....	page 59
System	
Date and Time.....	page 15
Network.....	page 11
Communication.....	page 13
Certificate.....	page 29
Remote Controller.....	page 31
Other.....	page 17
Maintenance	
Factory Reset and Restart	
Restart.....	page 19
Factory Reset.....	page 18
Software Update* <sup>2</sup> .....	page 20
Settings Data Migration	
Save Settings Data* <sup>2</sup> .....	page 22
Load Settings Data* <sup>2</sup> .....	page 23
License Activation* <sup>2</sup> .....	page 25
Event Rules.....	page 26
Hotkeys.....	page 33
User	
Local User.....	page 68
Add.....	page 68
Change.....	page 70
Delete.....	page 71
Auto Login Settings.....	page 72
LDAP* <sup>1</sup> .....	page 73
Troubleshooting	
Log Display	
Operation Log Display.....	page 35
System Log Display.....	page 36
Connection Confirmation.....	page 37
Network Connection Status.....	page 38

Live Image Screen Settings

Live Image Screen

Live Image Screen Settings ..... page 62  
System Status Settings ..... page 65  
Livestream View\*1 ..... page 66

\*1 Only available for use if the edition is Enterprise.  
\*2 This can be used only when displayed on the web browser.

# Appendix

## Trademark

The terms HDMI and HDMI High-Definition Multimedia Interface, and the HDMI Logo are trademarks or registered trademarks of HDMI Licensing, LLC in the United States and other countries.

VESA is a registered trademark of the Video Electronics Standards Association.

Microsoft and Internet Explorer are registered trademarks of Microsoft Corporation in the United States and other countries.

Adobe, Acrobat and Reader are registered trademarks of Adobe Systems Incorporated in the United States and other countries.

ONVIF is a trademark of ONVIF Inc.

Panasonic and i-pro are a registered trademark of Panasonic Corporation.

AXIS is a registered trademark of Axis AB in Sweden and other countries.

EIZO, the EIZO Logo, ColorEdge, CuratOR, DuraVision, FlexScan, FORIS, RadiCS, RadiForce, RadiNET, Raptor and ScreenManager are registered trademarks of EIZO Corporation in Japan and other countries.

ColorEdge Tablet Controller, ColorNavigator, EcoView NET, EIZO EasyPIX, EIZO Monitor Configurator, EIZO ScreenSlicer, G-Ignition, i-Sound, Quick Color Match, RadiLight, Re/Vue, SafeGuard, Screen Administrator, Screen InStyle, ScreenCleaner and UniColor Pro are trademarks of EIZO Corporation.

All other company names, product names, and logos are trademarks or registered trademarks of their respective companies.

## License

Some of the images in this manual are used with permission from Microsoft.

This product includes open source software.

If the open source software contains a product for which usage is granted under a GPL (GNU GENERAL PUBLIC LICENSE) license, EIZO Corporation will, in line with the GPL usage license conditions, provide the source code for corresponding GPL software via a medium, such as CD-ROM, at a cost to individuals and organizations who make contact via the following contact information for a minimum period of three years after purchase of the product.

We will also provide the source code for corresponding LGPL (GNU LESSER GENERAL PUBLIC LICENSE) software of products that include LGPL software licensed under the LGPL in the same manner as stated above.

### Contact information

[www.eizoglobal.com/contact/index.html](http://www.eizoglobal.com/contact/index.html)

\*Contact your local EIZO representative.

Except for open source software licensed under GPL, LPGL or other licenses, any transferring, copying, reverse assembly, reverse compiling or reverse engineering of any software included with this product is strictly prohibited. Further, exporting of any software included with this product in violation of applicable export laws is strictly prohibited.

This product falls within the scope of one or more claims of our patent listed in the following URL.

[patentlist.hevcadvance.com](http://patentlist.hevcadvance.com)



